

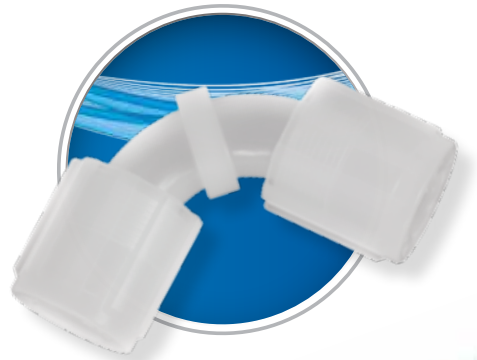

## High Purity PFA and PVDF Fittings

Innovative solutions for all of your fluid processing needs.

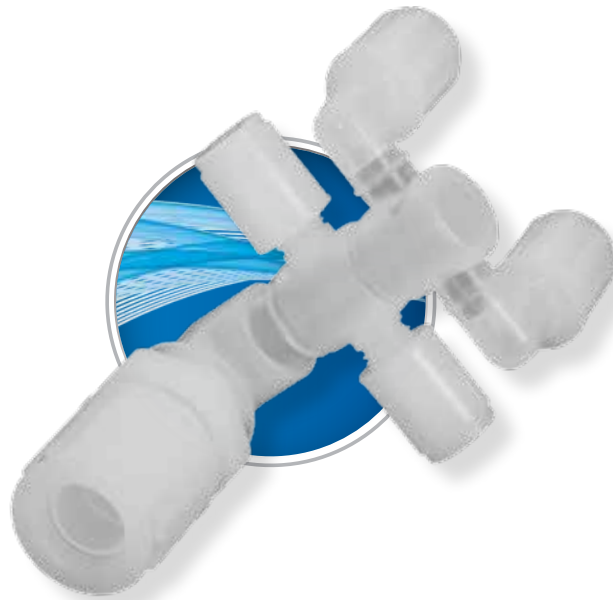

For more information, please visit: [FitLineInc.com](http://FitLineInc.com)

## TABLE OF CONTENTS

The Fit-Line Story .....	3-5	Union Tee (TightFLARE™) All .....	33
Mobile TruFLARE™ System .....	6	Male Run Tee .....	34
Bench Top TruFLARE™ System .....	7	Male Branch Tee (TightFLARE™) .....	34
TruFASTEN™ Torque Wrenches .....	8	Male Branch Tee .....	35
TruFASTEN™ Operating Instructions .....	9	Female Run Tee .....	36
Pressure vs. Temperature Graphs .....	10	Female Branch Tee .....	36
Male Connector .....	11	Flare Plug and Nut .....	37
Male Connector (TightFLARE™) .....	11	Flare Cap .....	37
Male Connector Panel Mount .....	12	Flare Nut PFA .....	38
Male Connector JIS .....	12	Flare Nut PVDF .....	38
Female Connector .....	13	Panel Mount Nut (Half Nut) PFA .....	38
Straight Union (Male Flare x Male Flare) .....	13	Panel Mount Nut (Half Nut) PVDF .....	38
Straight Union Reducer .....	14	Weld Straight Connector .....	39
Straight Union (TightFLARE™) .....	14	Weld Straight Connector (TightFLARE™) .....	39
Straight Union Panel Mount .....	15	Weld Elbow Connector .....	40
Straight Union Panel Mount Reducer .....	15	Weld Elbow Connector (TightFLARE™) .....	40
TightFLARE™ Union .....	16	Weld Straight Reducer .....	41
Flared PFA Tube Union .....	16	Weld Pipe Cap .....	41
TightFLARE™ Male Reducer .....	17	Weld Union Elbow .....	42
Application Example .....	17	Weld Union Tee .....	42
TightFLARE™ Female Reducer .....	18	Weld Male Adapter .....	43
TightFLARE™ Male Increaser .....	18	Weld Female Adapter .....	43
Double Containment Adapter .....	19	Weld Straight Reducer (Tube x Tube) .....	44
Double Containment Fittings Panel Mount Double Containment with O-Ring Containment Seal .....	19	Weld Elbow (Tube x Tube) .....	44
Male Elbow .....	20	Weld Elbow Reducer (Tube x Tube) .....	45
Male Elbow (TightFLARE™) .....	20	Weld Elbow Sweep (Tube x Tube) .....	45
Male Elbow JIS .....	21	Weld Tee (Tube x Tube x Tube) .....	46
Female Elbow .....	21	Weld Tee Reducer (Tube x Tube x Tube) .....	46
Union Elbow .....	22	Weld Cross (All Tube) .....	47
Union Elbow Reducer .....	22	Weld Cross Reducer (All Tube) .....	47
Union Elbow Panel Mount .....	23	Pipe Plug .....	48
Union Elbow (TightFLARE™) .....	23	Pipe Nipple .....	48
Union Elbow (TightFLARE™) .....	24	Female Male Connector Reducer .....	48
Union Elbow Reducer (TightFLARE™) .....	24	Reduced Orifice Fittings (Straight Union) .....	48
Union Elbow Sweep .....	25	Reduced Orifice Fittings (Male Connector) .....	48
Union Elbow Sweep (TightFLARE™) .....	25	Male Connector by Sanitary End .....	49
Union Elbow Sweep (TightFLARE™) .....	26	Union Elbow by Sanitary End .....	49
Male Elbow Sweep .....	26	Multi-Flare Panel Mount .....	50
Male Elbow Sweep (TightFLARE™) .....	27	Multi-Flare Male Connector .....	50
Union Tee .....	27	Multi-Flare Transition Fitting .....	51
Union Tee Reducer .....	28	Transition Fitting .....	51
Union Tee (TightFLARE™) Branch .....	29	GrabLOC™ Double Containment Fittings (Non-Terminating) .....	52
Union Tee (TightFLARE™) Run .....	30	GrabLOC™ Double Containment Fittings (Terminating) .....	53
Union Tee (TightFLARE™) Branch, Run .....	31	GrabLOC™ Double Containment Tee .....	54
Union Tee (TightFLARE™) Run, Run .....	32	WELDED Systems Fabricated Manifolds .....	55
		Warranty & Goods .....	56

## DESIGNING AND MANUFACTURING THE WORLD'S MOST PRECISE, LEAK-FREE FLUID SYSTEMS

**Because there's simply no other alternative.**

When it comes to your facility's fluid processing systems, the last thing you need to worry about is the quality and performance of your fittings.

Which is why it's essential to have the most precise, dependable, leak-proof solution in place to ensure your system will function flawlessly time and time again.

That's where Fit-LINE and our worldwide network of authorized distributors enter the picture. For over 25 years, Fit-LINE has designed, created and patented the most advanced and cost-effective fitting solutions

for a wide range of high-purity fluid processing applications—including end-users that require SEMI-F57-0301 compliant PFA and PVDF flare fittings.

Fit-LINE offers standard and custom fittings, from 1/8 inch up to 2 inch components, patented flaring systems, 3-D custom models and more. Fit-LINE provides you with innovative solutions for your most challenging and demanding fluid processing applications.



## INNOVATION STARTS HERE

**It's in our DNA. We've continuously evolved to conceive and patent some of the industry's most revolutionary products and innovative technology, including:**

- TruFLARE™ System, our patented “tube flaring machine”.
- TruFASTEN™, our ingenious preset torque wrenches that help ensure our flared fitting assemblies are leak-free.
- TightFLARE™, Fit-LINE's proprietary technology that creates repeatable “Female Flare” assemblies for tight spaces.

Fit-LINE is constantly developing and testing new ideas on a regular basis.

Need a custom solution? Having all of our manufacturing in-house and on-site allows us to take your custom idea from design to a working model in just a matter of days—instead of weeks like other suppliers.



## U.S. DESIGNED & MANUFACTURED SOLUTIONS FOR FLUID PROCESSING APPLICATIONS

At Fit-LINE, we engineer and supply the industry's most popular fitting configurations. That means when you need a fitting, it's available and ready to ship, allowing you to stay up and running and avoid costly delays.

From standard fittings and patented tube flaring systems, to customized designs that are developed, fabricated and tested in our state-of-the-art facility, Fit-LINE has the expertise and the know-how to ensure you get the most reliable, dependable components

delivered on time, all the time. At our core, we're a company of problem solvers.

Our employees are comprised of some of the best U.S. mechanical engineers, fabricators, senior toolmakers and process technicians with the curiosity, talent, insights and ideas to create the most advanced, dependable and leak-free solutions for all of your fluid processing needs.



## ONSITE PRECISION WHEN— AND WHERE—IT COUNTS

We saw the need for an on-site production flaring system that can produce precise, leak-free, repeatable tube flares. The solution? Our patented TruFLARE™ tube flaring system. TruFLARE™ and our Mobile TruFLARE™ system replicate the close tolerances consistent with our patented and proven TightFLARE™ technology. To date, application and installation usage has shown TruFLARE™ tube flaring technology to be far superior than all other existing flaring methods in the industry.

## FULL PRODUCT AND PACKAGING TRACEABILITY. ZERO COMPROMISES



Having our materials, manufacturing and packaging in a fully traceable, closed-source system ensures the highest level of protection, component quality and contamination control.

That's why Fit-LINE employs our own proprietary cleaning and packaging processes—including our five stage component cleaning and rinsing procedure—all

conducted in our very own Class 1000 Clean Room.

And when it comes to packaging, all of our fittings are double polyethylene bagged per SEMI-F57 standards. This will meet and exceed your exacting demands. Anything else simply won't do.



## DEDICATED TO YOU

At Fit-LINE, customer service goes beyond simply taking phone calls; Fit-LINE is your dedicated source for the solutions to all fluid processing needs. This means that as a valued Fit-LINE customer, you'll experience unmatched personalized attention, together with the highest quality components, all in a timely basis and at a fair price.

Simply put, Fit-LINE has the industry expertise and proven track record to deliver the world's most dependable, timely and leak-free solutions for your fluid processing applications.

# Mobile TruFLARE™ SYSTEM

Patented “Tube Flaring Machine”



The versatile mobile TruFLARE™ system is ideal for both in-house production and job site flaring. The patented heaters apply uniform heat around the tube to a controlled and repeatable length. Once the heat cycle is complete, the tube end is installed over the forming mandrel. The mandrels are engineered to extract heat evenly from the flared tube end. Applying controlled, uniform heat and extracting it evenly creates a stress-free “formed” flared end. This gives end users the flexibility to flare their tubes days in advance or quickly and consistently at the job site.

## KEY FEATURES

- Versatile flaring system, ideal for both in-house production and job site flaring.
- Ability to flare PFA and FEP tubing.<sup>1</sup>
- 15' long heater cord allows flaring in hard to reach places.
- Creates precise, concentric, repeatable tube flare ends.
- Automated touchscreen interface with preprogrammed tube settings.
- Exceptionally user-friendly.
- Consistent flares that hold their shape over time.

## PATENTED PRODUCT

Mobile TruFLARE™ Systems			
Tube Material	Mandrels	Voltage	Part No.
PFA	1/4, 3/8, 1/2, 3/4, 1	110 Volt	MTF416-110-A
PFA	1/4, 3/8, 1/2, 3/4, 1	220 Volt	MTF416-220-A
PFA	1-1/4	110 Volt	MTF20-110-A
PFA	1-1/4	220 Volt	MTF20-220-A
PFA	1-1/4, 1-1/2	110 Volt	MTF20-24-40MM-110-A+
PFA	1-1/4, 1-1/2	220 Volt	MTF20-24-40MM-220-A+
PFA	1/4, 3/8, 1/2, 3/4, 1	110 Volt	MTF416-110-P-A*
PFA	1/4, 3/8, 1/2, 3/4, 1	220 Volt	MTF416-200-P-A*

+ Special Order

\* PTFE Mandrels

# Bench Top TruFLARE™ SYSTEM

Patented “Tube Flaring Machine”



Uniquely engineered, semi-automated bench top flaring system. Creates a standard tube flare end by pressure forming and rapidly cooling the flare form. The bench top TruFLARE™ system is ideal for production flaring. It assures precise, concentric, repeatable tube flare connections. This requires no immediate assembly, which is often the case with other rudimentary hot flaring systems.

## KEY FEATURES

- Ideal for production flaring.
- Create precise, concentric, repeatable tube flare ends.
- Automated touchscreen interface with preprogrammed tube settings.
- Exceptionally user-friendly.
- Consistent flares that hold their shape over time.

## PATENTED PRODUCT

Tube Material	Flare Mandrel Sizes	Voltage	Part No.
PFA	1/4, 3/8, 1/2, 3/4, 1	110 Volt	TF416-110-A
PFA	1/4, 3/8, 1/2, 3/4, 1	220 Volt	TF416-220-A

For more flaring options, visit: [FitLineInc.com](http://FitLineInc.com)

**AUTOMATED TOUCHSCREEN INTERFACE**

Select tube size and the controller will automatically set the required heat temperature, heat time and cure time.



# TruFASTEN™ OPERATING INSTRUCTIONS



# TruFASTEN™ TORQUE WRENCHES

Fastens PFA and PVDF nuts to the required torque value which ensures leak-free flared fitting assemblies.

## KEY FEATURES

- Wrenches are calibrated to preset torque values based on nut size.
- Wrench claw clicks over when required torque value is reached.
- Ratcheting action allows the nut to be rapidly tightened, making jobs easier and faster.
- Wrenches fit in the palm of a hand easily allowing use in hard to reach places.
- Available for PFA and PVDF nuts.
- U.S. and foreign patents pending.

TruFASTEN™ Torque Wrenches Patent Pending		
Nut Size	PFA Part No.	PVDF Part No.
1/4	TFW4-3	TFW4-1
3/8	TFW6-3	TFW6-1
1/2	TFW8-3	TFW8-1
3/4	TFW12-3	TFW12-1
1	TFW16-3	TFW16-1
Complete Set (All sizes listed above)	TFWS-3	TFWS-1

Color coded handles: **Blue** for PFA **Red** for PVDF

### RATCHETING ACTION

Rapidly tighten nuts to make assemblies easier and faster.

### CLICK OVER FEATURE

The claw clicks over when wrench reaches required torque value.

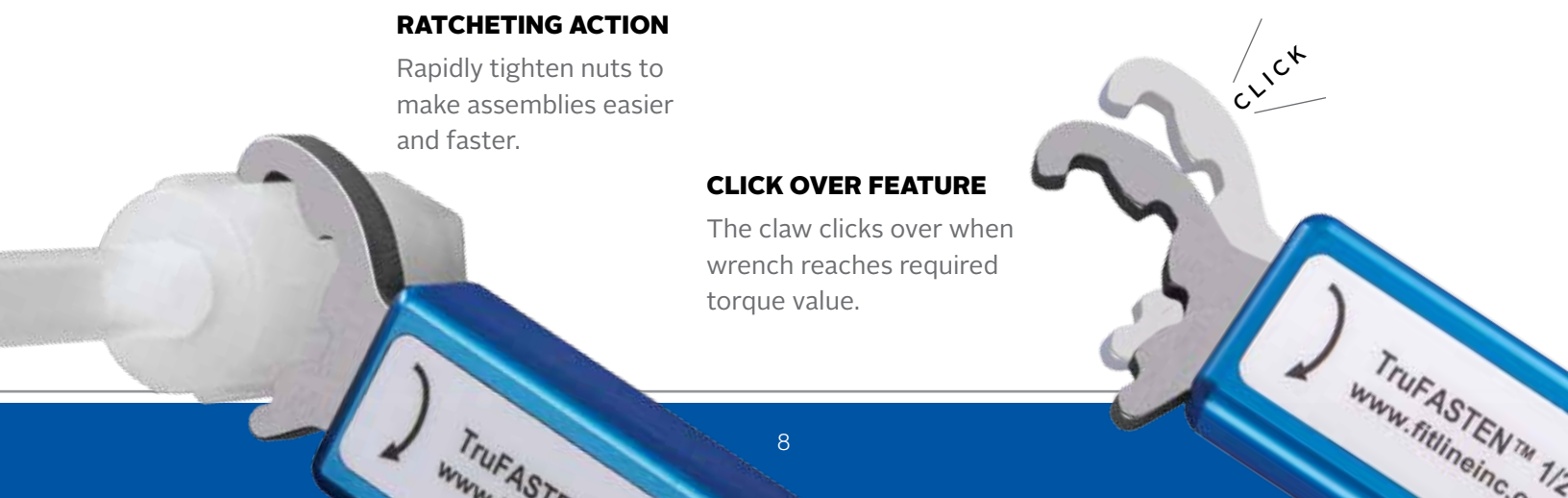

## STEP 1

- Make sure claw is in start position, as shown below in picture A.
- Align teeth on claw with splines on nut, as shown here in Step 1.
- Grip handle firmly and rotate clockwise to tighten nut.



## STEP 2

- Rotate handle in a counter clockwise direction, as shown here in Step 2.
- Grip next set of splines with claw and rotate clockwise.
- Continue steps 1 and 2 until claw clicks over, as shown in Step 3 and picture B.



## STEP 3

- Snap claw back to its Start Position, as shown in picture A.
- Tighten nut one more time until claw clicks over.

**Note: Nut must be tightened twice with wrench.**



## PICTURE A.

START POSITION



## PICTURE B.

FINISH POSITION

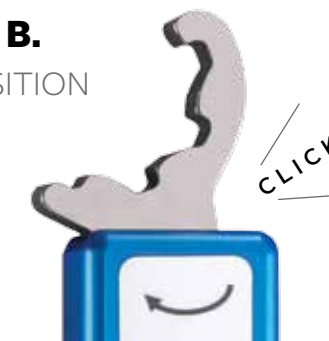

# Pressure vs. Temperature Graphs

**PFA Fittings  
Pressure vs. Temperature**

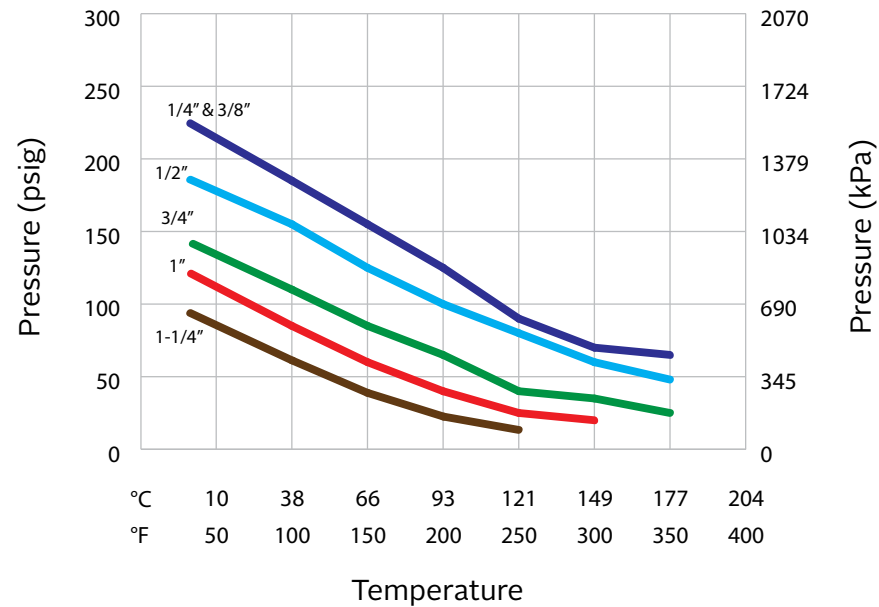

Pressure ratings for 1/4" flares are based on 0.047" wall tubing; 3/8", 1/2", 3/4" and 1" flares are based on 0.062" wall tubing and 1-1/4" flares are based on 0.075" wall tubing.

**PVDF Fittings  
Pressure vs. Temperature**

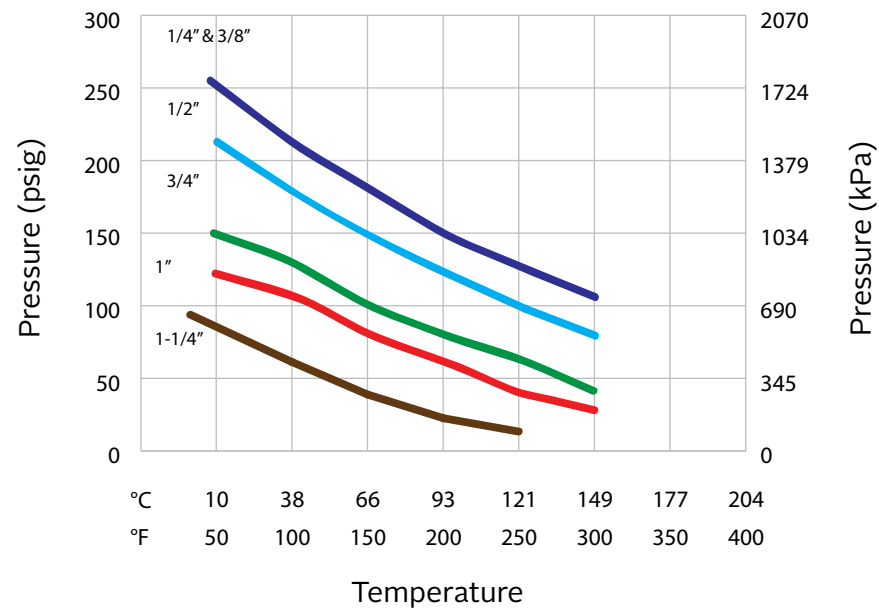

Pressure ratings for 1/4" flares are based on 0.047" wall tubing; 3/8", 1/2", 3/4" and 1" flares are based on 0.062" wall tubing and 1-1/4" flares are based on 0.075" wall tubing.

**WARNING: PVDF not for use in applications exceeding 248° F (120° C)**

Fit-LINE is not responsible for product damage due to accidents, misuse, or improper application usage.

Male Connector (Male Flare x MNPT)								
PFA Part No.	PVDF Part No.	Tube O.D.	MNPT Size	Orifice	A	B	C	Hex
MC4-2N-1	MC4-2	1/4	1/8	.15	1.91	.97	.45	5/8
MC4-4N-1	MC4-4	1/4	1/4	.15	2.00	.97	.55	5/8
MC4-6N-1	MC4-6	1/4	3/8	.15	2.00	.97	.55	11/16
MC4-8N-1	MC4-8	1/4	1/2	.15	2.12	.97	.66	13/16
MC4-12N-1		1/4	3/4	.15	2.12	.97	.67	1-3/16
MC4-16N-1		1/4	1	.15	2.32	.97	.85	1-7/16
MC6-2N-1		3/8	1/8	.18	2.09	1.04	.55	13/16
MC6-4N-1	MC6-4	3/8	1/4	.25	2.11	1.04	.55	13/16
MC6-6N-1	MC6-6	3/8	3/8	.25	2.11	1.04	.55	13/16
MC6-8N-1	MC6-8	3/8	1/2	.25	2.21	1.04	.66	15/16
MC6-12N-1	MC6-12	3/8	3/4	.25	2.22	1.04	.66	1-3/16
MC6-16N-1		3/8	1	.25	2.39	1.04	.85	1-7/16
MC8-2N-1		1/2	1/8	.18	2.20	1.14	.54	15/16
MC8-4N-1	MC8-4	1/2	1/4	.38	2.20	1.14	.55	15/16
MC8-6N-1	MC8-6	1/2	3/8	.38	2.20	1.14	.55	15/16
MC8-8N-1	MC8-8	1/2	1/2	.38	2.32	1.14	.66	15/16
MC8-12N-1	MC8-12	1/2	3/4	.38	2.32	1.14	.66	1-3/16
MC8-16N-1		1/2	1	.38	2.51	1.14	.86	1-7/16
MC12-6N-1		3/4	3/8	.38	2.37	1.29	.56	15-16
MC12-8N-1	MC12-8	3/4	1/2	.51	2.48	1.29	.67	1-3/16
MC12-12N-1	MC12-12	3/4	3/4	.63	2.48	1.29	.67	1-3/16
MC12-16N-1	MC12-16	3/4	1	.63	2.66	1.29	.85	1-7/16
MC16-8N-1		1	1/2	.51	2.69	1.46	.67	1-7/16
MC16-12N-1	MC16-12	1	3/4	.66	2.69	1.46	.67	1-7/16
MC16-16N-1	MC16-16	1	1	.88	2.88	1.46	.86	1-7/16
MC20-16N-1		1-1/4	1	.97	3.29	1.75	.86	1-3/4
MC20-20N-1		1-1/4	1-1/4	1.10	3.29	1.75	.86	1-3/4

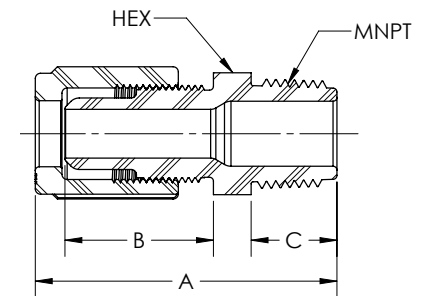

Male Connector (TightFLARE™) (Female Flare x MNPT) Patented							
PFA Part No.	TightFLARE	MNPT Size	Orifice	A	B	C	Hex
MC4T-2N-1	1/4	1/8	.15	2.16	.53	.45	5/8
MC4T-4N-1	1/4	1/4	.15	2.13	.53	.55	5/8
MC4T-6N-1	1/4	3/8	.15	2.13	.53	.55	11/16
MC4T-8N-1	1/4	1/2	.15	2.27	.53	.67	13/16
MC6T-4N-1	3/8	1/4	.25	2.22	.52	.56	13/16
MC6T-6N-1	3/8	3/8	.25	2.22	.53	.55	13/16
MC6T-8N-1	3/8	1/2	.25	2.33	.52	.67	13/16
MC8T-4N-1	1/2	1/4	.25	2.28	.53	.56	15/16
MC8T-6N-1	1/2	3/8	.38	2.26	.53	.55	13/16
MC8T-8N-1	1/2	1/2	.38	2.47	.53	.67	15/16
MC12T-8N-1	3/4	1/2	.51	2.57	.56	.67	1-3/16
MC12T-12N-1	3/4	3/4	.63	2.57	.56	.67	1-3/16
MC12T-16N-1	3/4	1	.63	2.76	.56	.86	1-7/16
MC16T-16N-1	1	1	.88	2.99	.50	.86	1-7/16

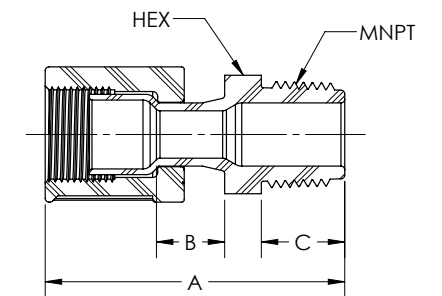

Male Connector Panel Mount (Male Flare x MNPT)											
PFA Part No.	PVDF Part No.	Tube O.D.	MNPT Size	Orifice	A	B	C	D (Max)	Hex 1	Hex 2	Minimum Panel Hole Diameter
MCPM4-2N-1		1/4	1/8	.15	2.78	1.73	.55	.50	3/4	11/16	1/2
MCPM4-4N-1	MCPM4-4	1/4	1/4	.15	2.78	1.73	.55	.50	3/4	11/16	1/2
MCPM4-6N-1		1/4	3/8	.15	2.78	1.73	.55	.50	3/4	11/16	1/2
MCPM6-4N-1	MCPM6-4	3/8	1/4	.25	2.87	1.83	.55	.50	15/16	13/16	5/8
MCPM6-6N-1		3/8	3/8	.25	2.87	1.83	.55	.50	15/16	13/16	5/8
MCPM8-4N-1		1/2	1/4	.38	2.99	1.94	.55	.50	1-1/16	15/16	3/4
MCPM8-6N-1		1/2	3/8	.38	2.99	1.94	.55	.50	1-1/16	15/16	3/4
MCPM8-8N-1	MCPM8-8	1/2	1/2	.38	3.10	1.94	.67	.50	1-1/16	15/16	3/4
MCPM12-12N-1	MCPM12-12	3/4	3/4	.63	3.26	2.06	.68	.50	1-5/16	1-3/16	1
MCPM16-16N-1		1	1	.88	3.66	2.21	.86	.50	1-3/4	1-5/8	1-7/16

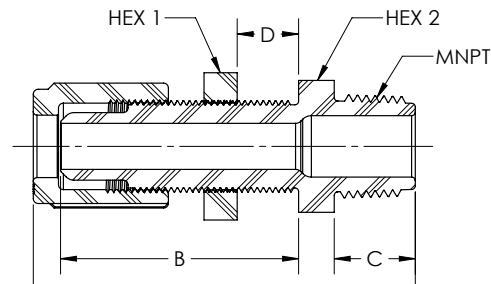

Female Connector (Male Flare x FNPT)								
PFA Part No.	PVDF Part No.	Tube O.D.	FNPT Size	Orifice	A	B	C	Hex
FC4-2N-1	FC4-2	1/4	1/8	.15	1.90	.97	.79	5/8
FC4-4N-1	FC4-4	1/4	1/4	.15	1.99	.97	.84	3/4
FC4-6N-1	FC4-6	1/4	3/8	.15	2.00	.97	.92	15/16
FC4-8N-1		1/4	1/2	.15	2.02	.97	.86	1-1/8
FC6-2N-1		3/8	1/8	.25	1.78	1.04	.74	5/8
FC6-4N-1	FC6-4	3/8	1/4	.25	2.05	1.04	.84	3/4
FC6-6N-1	FC6-6	3/8	3/8	.25	2.10	1.04	.84	15/16
FC6-8N-1	FC6-8	3/8	1/2	.25	2.13	1.04	.86	1-1/8
FC8-4N-1		1/2	1/4	.38	2.18	1.14	.84	3/4
FC8-6N-1	FC8-6	1/2	3/8	.38	2.20	1.14	.87	15/16
FC8-8N-1	FC8-8	1/2	1/2	.38	2.22	1.14	.86	1-1/8
FC8-12N-1	FC8-12	1/2	3/4	.38	2.28	1.14	.92	1-3/8
FC8-16N-1		1/2	1	.38	2.50	1.14	1.14	1-5/8
FC12-8N-1	FC12-8	3/4	1/2	.63	2.38	1.29	.86	1-1/8
FC12-12N-1	FC12-12	3/4	3/4	.63	2.44	1.29	.92	1-3/8
FC12-16N-1		3/4	1	.63	2.66	1.29	1.14	1-5/8
FC16-16N-1	FC16-16	1	1	.88	2.88	1.46	1.14	1-5/8

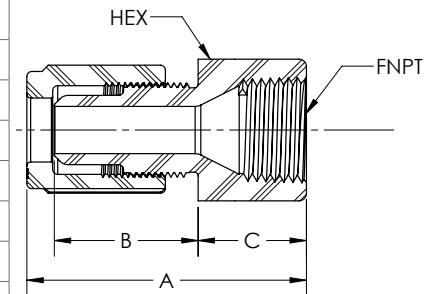

Male Connector JIS (Male Flare x Metric Pipe)							
PFA Part No.	Tube O.D.	JIS Size	Orifice	A	B	C	Hex
MC4-4JN-1	1/4	1/4	.15	2.00	.97	.56	5/8
MC4-6JN-1	1/4	3/8	.15	2.00	.97	.56	11/16
MC4-8JN-1	1/4	1/2	.15	2.11	.97	.66	15/16
MC6-4JN-1	3/8	1/4	.25	2.11	1.04	.56	13/16
MC6-6JN-1	3/8	3/8	.25	2.11	1.04	.56	13/16
MC6-8JN-1	3/8	1/2	.25	2.22	1.04	.67	15/16
MC8-4JN-1	1/2	1/4	.38	2.20	1.14	.56	15/16
MC8-6JN-1	1/2	3/8	.38	2.20	1.14	.56	15/16
MC8-8JN-1	1/2	1/2	.38	2.32	1.14	.67	15/16
MC8-12JN-1	1/2	3/4	.38	2.32	1.14	.68	1-3/16
MC12-6JN-1	3/4	3/8	.63	2.37	1.29	.56	1-3/16
MC12-8JN-1	3/4	1/2	.51	2.48	1.29	.67	1-3/16
MC12-12JN-1	3/4	3/4	.63	2.49	1.29	.67	1-3/16
MC12-16JN-1	3/4	1	.63	2.65	1.29	.85	1-7/16
MC16-12JN-1	1	3/4	.66	2.69	1.46	.67	1-7/16
MC16-16JN-1	1	1	.88	2.87	1.46	.85	1-7/16

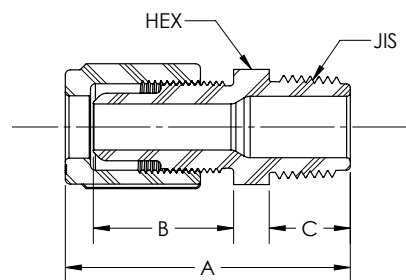

Straight Union (Male Flare x Male Flare)						
PFA Part No.	PVDF Part No.	Tube O.D.	Orifice	A	B	Hex
SU44N-1	SU44	1/4	.15	2.62	.97	11/16
SU66N-1	SU66	3/8	.25	2.83	1.04	13/16
SU88N-1	SU88	1/2	.38	3.02	1.14	15/16
SU1212N-1	SU1212	3/4	.63	3.32	1.29	1-3/16
SU1616N-1	SU1616	1	.88	3.72	1.46	1-7/16
SU2020N-1		1-1/4	1.10	4.88	1.75	1-3/4

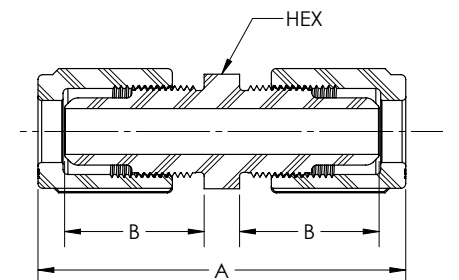

**Straight Union Reducer**  
(Male Flare x Male Flare)

PFA Part No.	PVDF Part No.	Tube O.D.	Tube O.D.	A	B	C	Hex
SU64N-1	SU64	3/8	1/4	2.72	1.04	.97	11/16
SU84N-1		1/2	1/4	2.82	1.14	.97	15/16
SU86N-1	SU86	1/2	3/8	2.92	1.14	1.04	15/16
SU124N-1		3/4	1/4	2.96	1.29	.97	1-3/16
SU126N-1		3/4	3/8	3.07	1.29	1.05	1-3/16
SU128N-1	SU128	3/4	1/2	3.17	1.29	1.14	1-3/16
SU164N-1		1	1/4	3.17	1.46	.97	1-7/16
SU168N-1		1	1/2	3.38	1.45	1.14	1-7/16
SU1612N-1		1	3/4	3.53	1.46	1.29	1-7/16
SU2016N-1		1-1/4	1	4.36	1.75	1.51	1-3/4

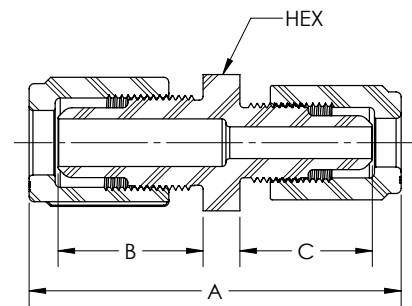

**Straight Union (TightFLARE™)**  
(Male Flare x Female Flare)  
Patented

PFA Part No.	Tube O.D. / TightFLARE	Orifice	A	B	C	Hex
SU44TN-1	1/4	.15	2.76	.97	.53	11/16
SU66TN-1	3/8	.25	2.93	1.04	.52	13/16
SU88TN-1	1/2	.38	3.07	1.14	.51	15/16
SU1212TN-1	3/4	.63	3.41	1.29	.56	1-3/16
SU1616TN-1	1	.88	4.04	1.46	.50	1-7/16

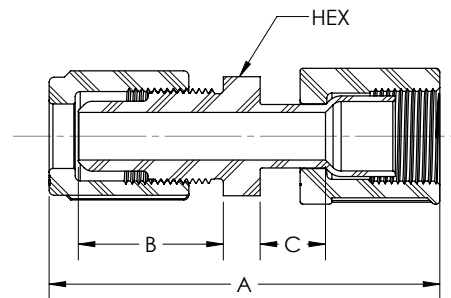

**Straight Union Panel Mount**  
(Male Flare x Male Flare)

PFA Part No.	PVDF Part No.	Tube O.D.	Orifice	A	B	C	D (Max)	Hex 1	Hex 2	Minimum Panel Hole Diameter
SPM44N-1	SPM44	1/4	.15	3.40	1.73	.97	.50	3/4	11/16	1/2
SPM66N-1	SPM66	3/8	.25	3.58	1.83	1.04	.50	15/16	13/16	5/8
SPM88N-1	SPM88	1/2	.38	3.80	1.94	1.14	.50	1-1/16	15/16	3/4
SPM1212N-1	SPM1212	3/4	.63	4.11	2.06	1.29	.50	1-5/16	1-3/16	1
SPM1616N-1	SPM1616	1	.88	4.53	2.21	1.46	.50	1-3/4	1-5/8	1-7/16

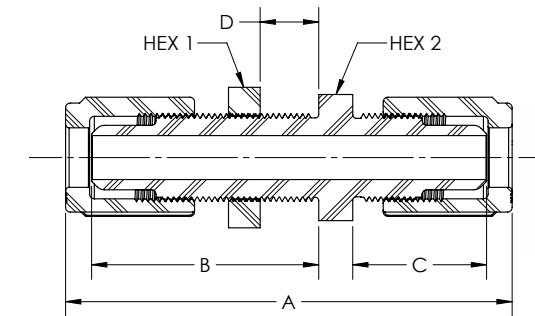

**Straight Union Panel Mount Reducer**  
(Male Flare x Male Flare)

PFA Part No.	PVDF Part No.	Tube O.D.	Tube O.D.	Orifice	A	B	C	D (Max)	Hex 1	Hex 2	Minimum Panel Hole Diameter
SPM64N-1	SPM64	3/8	1/4	.15	3.48	1.83	.97	.50	15/16	13/16	5/8
SPM84N-1		1/2	1/4	.15	3.59	1.94	.97	.50	1-1/16	15/16	3/4
SPM86N-1	SPM86	1/2	3/8	.25	3.70	1.94	1.04	.50	1-1/16	15/16	3/4
SPM126N-1		3/4	3/8	.25	3.86	2.06	1.04	.50	1-5/16	1-3/16	1
SPM128N-1	SPM128	3/4	1/2	.38	3.95	2.06	1.14	.50	1-5/16	1-3/16	1
SPM1612N-1		1	3/4	.63	4.31	2.21	1.29	.50	1-3/4	1-5/8	1-7/16

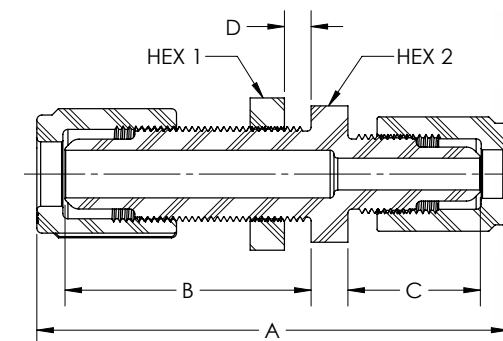



TightFLARE™ Union (Female Flare x Female Flare) Patented						
PFA Part No.	TightFLARE	Orifice	A	B	C	D
TFU4N-1	1/4	.15	.84	1.03	.36	.78
TFU6N-1	3/8	.25	.86	1.10	.38	.91
TFU8N-1	1/2	.38	.93	1.15	.38	1.03
TFU12N-1	3/4	.63	.90	1.32	.38	1.35
TFU16N-1	1	.88	1.05	1.50	.52	1.76
TFU20N-1	1-1/4	1.10	1.03	1.83	.52	2.20

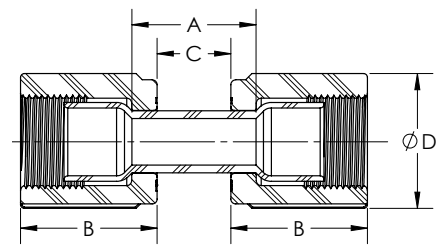
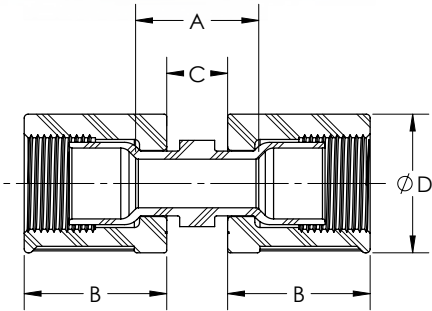

Flared PFA Tube Union (Female Flare x Female Flare)							
PVDF Nut Part No.	PFA Nut Part No.	TightFLARE	Orifice	A	B	C	D
FTU4N-1-53	FTU4N-3-53	1/4	.15	.53	1.03	.14	.78
FTU4N-1-88	FTU4N-3-88	1/4	.15	.88	1.03	.50	.78
FTU4N-1-336	FTU4N-3-336	1/4	.15	3.36	1.03	2.38	.78
FTU6N-1-51	FTU6N-3-51	3/8	.25	.51	1.10	.13	.91
FTU6N-1-88	FTU6N-3-88	3/8	.25	.88	1.10	.50	.91
FTU8N-1-47	FTU8N-3-47	1/2	.38	.47	1.15	.09	1.03
FTU8N-1-88	FTU8N-3-88	1/2	.39	.88	1.15	.50	1.03
FTU8N-1-269	FTU8N-3-269	1/2	.40	2.69	1.15	2.31	1.03
FTU8N-1-382	FTU8N-3-382	1/2	.41	3.82	1.15	3.44	1.03
FTU12N-1-59	FTU12N-3-59	3/4	.63	.59	1.32	.12	1.35
FTU12N-1-97	FTU12N-3-97	3/4	.63	.97	1.32	.50	1.35
FTU12N-1-378	FTU12N-3-378	3/4	.63	3.78	1.32	3.31	1.35
FTU16N-1-68	FTU16N-3-68	1	.88	.68	1.50	.15	1.76
FTU16N-1-103	FTU16N-3-103	1	.88	1.03	1.50	.50	1.76
FTU16N-1-272	FTU16N-3-272	1	.88	2.72	1.50	2.19	1.76

Custom "A" dimensions available upon request. Email: info@FitLineInc.com

TightFLARE™ Male Reducer (Female Flare x Male Flare) Patented				
PFA Part No.	TightFLARE	Tube O.D.	Orifice	A
TFMR64N-1	3/8	1/4	.15	1.13
TFMR84N-1	1/2	1/4	.15	1.19
TFMR86N-1	1/2	3/8	.25	1.21
TFMR124N-1	3/4	1/4	.15	1.07
TFMR126N-1	3/4	3/8	.25	1.16
TFMR128N-1	3/4	1/2	.38	1.24
TFMR164N-1	1	1/4	.15	1.03
TFMR166N-1	1	3/8	.25	1.11
TFMR168N-1	1	1/2	.38	1.20
TFMR1612N-1	1	3/4	.63	1.31
TFMR204N-1	1-1/4	1/4	.15	1.07
TFMR206N-1	1-1/4	3/8	.25	1.16
TFMR208N-1	1-1/4	1/2	.38	1.24
TFMR2012N-1	1-1/4	3/4	.63	1.31
TFMR2016N-1	1-1/4	1	.88	1.75

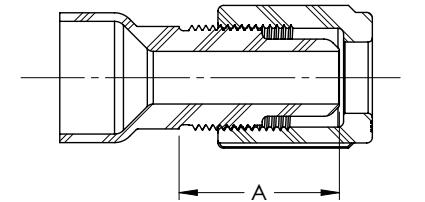

**TIGHTFLARE™ MALE REDUCER ASSEMBLY**

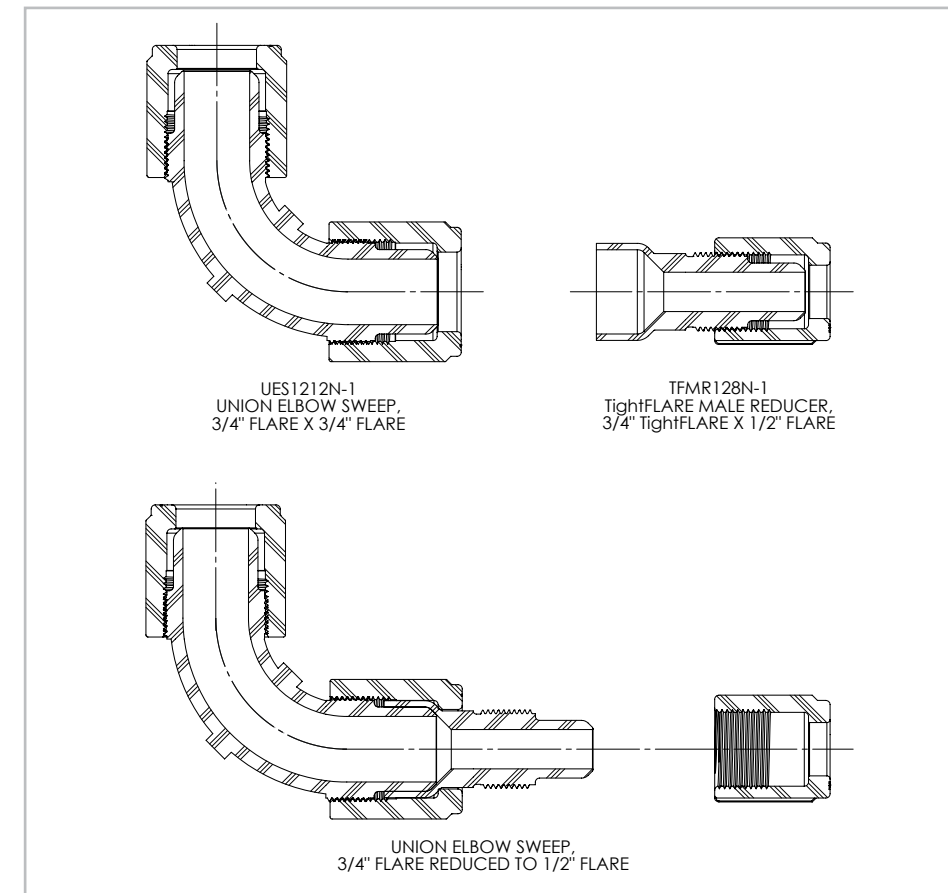



TightFLARE™ Female Reducer (Female Flare x Female Flare) Patented				
PFA Part No.	TightFLARE 1	TightFLARE 2	Orifice	A
TFFR64N-1	3/8	1/4	.15	.76
TFFR84N-1	1/2	1/4	.15	.80
TFFR86N-1	1/2	3/8	.25	.68
TFFR124N-1	3/4	1/4	.15	.92
TFFR126N-1	3/4	3/8	.25	.68
TFFR128N-1	3/4	1/2	.38	.75
TFFR164N-1	1	1/4	.15	.95
TFFR166N-1	1	3/8	.25	.92
TFFR168N-1	1	1/2	.38	.93
TFFR1612N-1	1	3/4	.63	.95

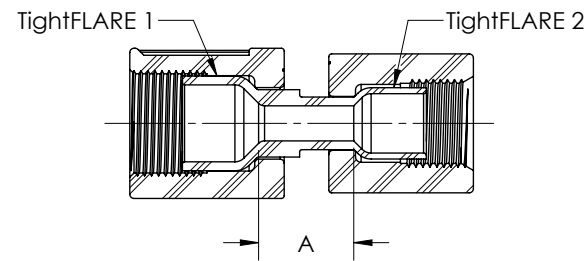

TightFLARE™ Male Increaser (Female Flare x Male Flare) Patented							
PFA Part No.	TightFLARE	Tube O.D.	Orifice	A	B	C	Hex
TFMI46N-1	1/4	3/8	.15	2.88	.53	1.04	13/16
TFMI48N-1	1/4	1/2	.15	2.97	.53	1.14	15/16
TFMI68N-1	3/8	1/2	.25	3.03	.52	1.14	15/16
TFMI612N-1	3/8	3/4	.25	3.19	.52	1.29	1-3/16
TFMI812N-1	1/2	3/4	.38	3.23	.53	1.29	1-3/16
TFMI816N-1	1/2	1	.38	3.44	.53	1.46	1-7/16
TFMI1216N-1	3/4	1	.63	3.66	.56	1.46	1-7/16
TFMI1620N-1	1	1-1/4	.88	4.39	.46	1.75	1-3/4

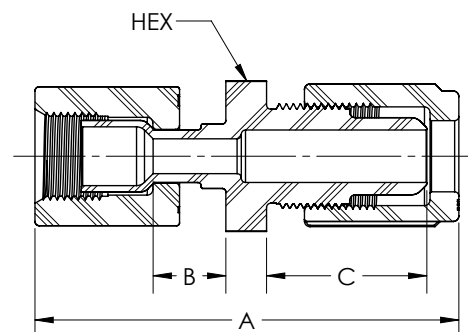

Double Containment Adapter (Male Flare)						
PVDF Part No.	Primary O.D.	Containment O.D.	A	B	C	Hex
DC48	1/4	1/2	1.40	.50	1.03	15/16
DC612	3/8	3/4	1.78	.73	1.35	1-3/16
DC812	1/2	3/4	1.78	.73	1.35	1-3/16
DC1216	3/4	1	2.04	.70	1.82	1-9/16

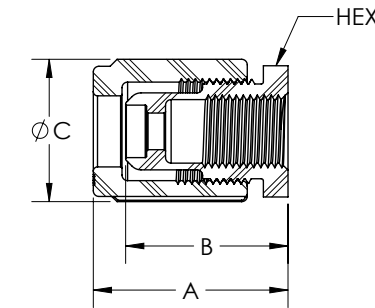

Double Containment Fittings Panel Mount Double Containment with O-Ring Containment Seal (Male Flare x Male Flare)										
PFA Part No.	Primary O.D.	Containment O.D.	Orifice	A	B	C	D	Hex 1	Hex 2	Minimum Panel Hole Diameter
PM44DC8N-1	1/4	1/2	.15	3.60	1.53	2.07	.25	3/4	11/16	1/2
PM66DC12N-1	3/8	3/4	.25	3.95	1.63	2.32	.25	1-5/16	13/16	5/8
PM88DC12N-1	1/2	3/4	.38	4.15	1.73	2.42	.25	1-1/16	15/16	3/4
PM1212DC16N-1	3/4	1	.63	4.58	1.88	2.70	.25	1-5/16	1-3/16	1

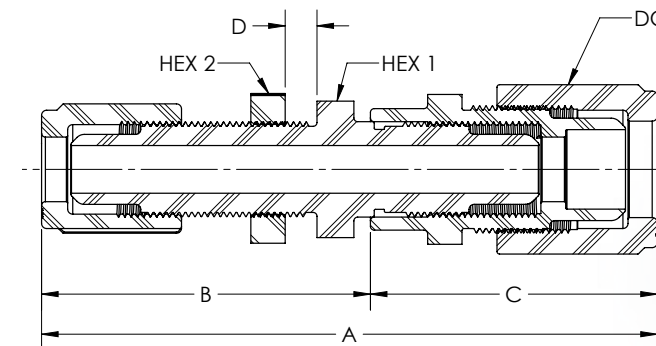

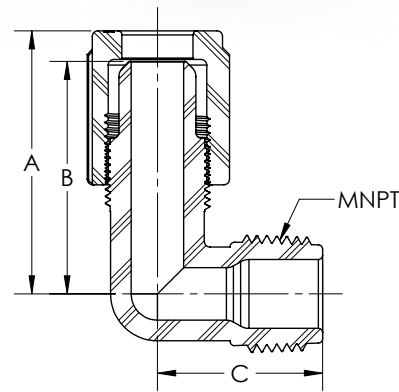

Male Elbow (Male Flare x MNPT)							
PFA Part No.	PVDF Part No.	Tube O.D.	MNPT Size	Orifice	A	B	C
ME4-2N-1	ME4-2	1/4	1/8	.15	1.66	1.47	1.06
ME4-4N-1	ME4-4	1/4	1/4	.15	1.66	1.47	1.06
ME4-6N-1	ME4-6	1/4	3/8	.15	1.66	1.47	1.06
ME4-8N-1		1/4	1/2	.15	1.66	1.47	1.17
ME6-2N-1		3/8	1/8	.18	1.76	1.53	1.06
ME6-4N-1	ME6-4	3/8	1/4	.25	1.76	1.53	1.06
ME6-6N-1	ME6-6	3/8	3/8	.25	1.76	1.53	1.06
ME6-8N-1	ME6-8	3/8	1/2	.25	1.76	1.53	1.18
ME6-12N-1		3/8	3/4	.25	1.76	1.53	1.36
ME8-2N-1		1/2	1/8	.18	1.86	1.64	1.06
ME8-4N-1		1/2	1/4	.25	1.86	1.64	1.06
ME8-6N-1	ME8-6	1/2	3/8	.38	1.86	1.64	1.06
ME8-8N-1	ME8-8	1/2	1/2	.38	1.86	1.64	1.18
ME8-12N-1	ME8-12	1/2	3/4	.49	1.86	1.64	1.36
ME8-16N-1		1/2	1	.38	1.86	1.64	1.80
ME12-6N-1		3/4	3/8	.36	2.21	1.98	1.23
ME12-8N-1	ME12-8	3/4	1/2	.53	2.21	1.98	1.36
ME12-12N-1	ME12-12	3/4	3/4	.63	2.21	1.98	1.37
ME12-16N-1	ME12-16	3/4	1	.63	2.21	1.98	1.80
ME16-8N-1		1	1/2	.51	2.70	2.43	1.37
ME16-12N-1	ME16-12	1	3/4	.66	2.70	2.43	1.64
ME16-16N-1	ME16-16	1	1	.87	2.70	2.43	1.80

Male Elbow (TightFLARE™) (Female Flare x MNPT) Patented							
PFA Part No.	TightFLARE Size	MNPT Size	Orifice	A	B	C	
ME4T-4N-1	1/4	1/4	.15	1.66	1.47	1.06	
ME6T-6N-1	3/8	3/8	.25	1.76	1.53	1.06	
ME8T-8N-1	1/2	1/2	.38	1.85	1.63	1.18	
ME12T-12N-1	3/4	3/4	.63	1.76	1.53	1.36	
ME16T-16N-1	1	1	.88	1.76	1.49	1.18	

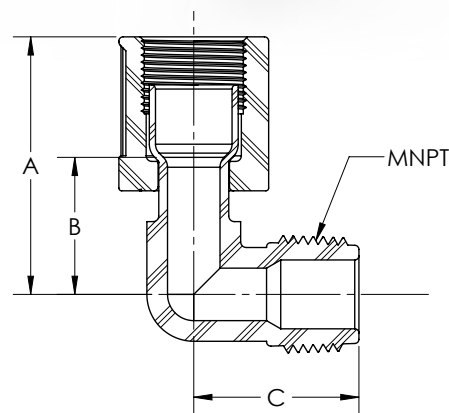

Male Elbow JIS (Male Flare x Metric Pipe)						
PFA Part No.	Tube O.D.	JIS Size	Orifice	A	B	C
ME4-4JN-1	1/4	1/4	.15	1.66	1.47	1.06
ME4-6JN-1	1/4	3/8	.15	1.66	1.47	1.06
ME6-4JN-1	3/8	1/4	.25	1.76	1.53	1.06
ME6-6JN-1	3/8	3/8	.25	1.76	1.53	1.06
ME6-8JN-1	3/8	1/2	.25	1.76	1.53	1.18
ME8-4JN-1	1/2	1/4	.25	1.86	1.64	1.06
ME8-6JN-1	1/2	3/8	.38	1.86	1.64	1.06
ME8-8JN-1	1/2	1/2	.38	1.86	1.64	1.18
ME8-12JN-1	1/2	3/4	.38	1.86	1.64	1.36
ME12-8JN-1	3/4	1/2	.53	2.21	1.98	1.36
ME12-12JN-1	3/4	3/4	.63	2.21	1.98	1.37
ME12-16JN-1	3/4	1	.63	2.21	1.98	1.80
ME16-12JN-1	1	3/4	.66	2.70	2.43	1.64
ME16-16JN-1	1	1	.87	2.70	2.43	1.80

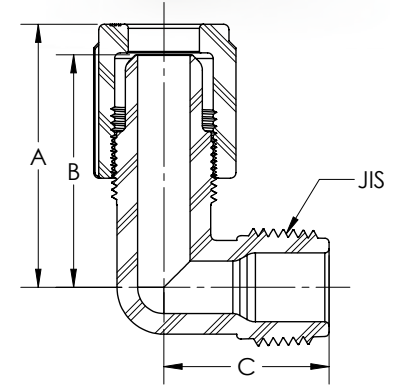

Female Elbow (Male Flare x FNPT)							
PFA Part No.	PVDF Part No.	Tube O.D.	FNPT Size	Orifice	A	B	C
FE4-2N-1	FE4-2	1/4	1/8	.15	1.80	1.61	.81
FE4-4N-1	FE4-4	1/4	1/4	.15	1.80	1.61	.94
FE4-6N-1	FE4-6	1/4	3/8	.15	1.80	1.61	1.00
FE4-8N-1		1/4	1/2	.15	1.80	1.61	1.25
FE6-4N-1	FE6-4	3/8	1/4	.25	1.91	1.68	.94
FE6-6N-1	FE6-6	3/8	3/8	.25	1.91	1.68	1.00
FE6-8N-1	FE6-8	3/8	1/2	.25	1.91	1.68	1.25
FE8-4N-1		1/2	1/4	.36	2.03	1.81	.96
FE8-6N-1	FE8-6	1/2	3/8	.38	2.03	1.81	1.00
FE8-8N-1	FE8-8	1/2	1/2	.38	2.03	1.81	1.27
FE8-12N-1		1/2	3/4	.38	2.03	1.81	1.53
FE12-8N-1		3/4	1/2	.54	2.22	1.99	1.44
FE12-12N-1		3/4	3/4	.63	2.22	1.99	1.53
FE16-16N-1		1	1	.88	2.67	2.40	1.60

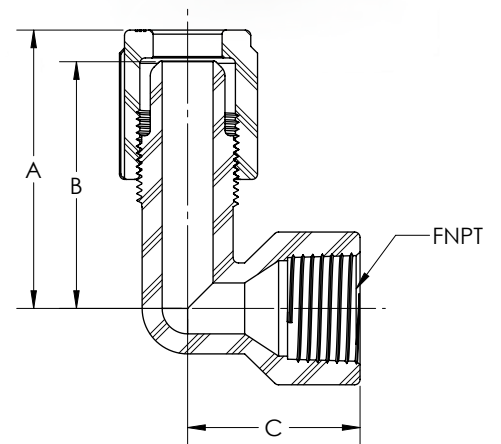



Union Elbow (Male Flare x Male Flare)					
PFA Part No.	PVDF Part No.	Tube	Orifice	A	B
UE44N-1	UE44	1/4	.15	1.66	1.47
UE66N-1	UE66	3/8	.25	1.76	1.53
UE88N-1	UE88	1/2	.38	1.87	1.65
UE1212N-1	UE1212	3/4	.63	2.22	1.99
UE1616N-1	UE1616	1	.87	2.70	2.43
UE2020N-1		1-1/4	1.10	2.96	2.65

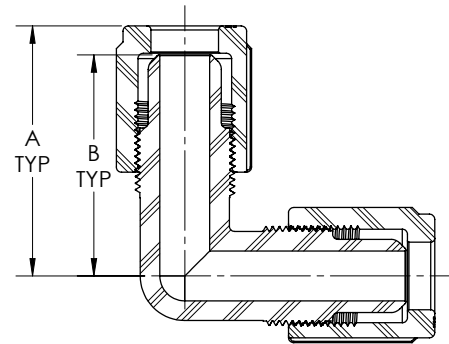

Union Elbow Panel Mount (Male Flare x Male Flare)								
PFA Part No.	Tube O.D.	Orifice	A	B	C	D	E	Minimum Panel Hole Diameter
EPMX44N-1	1/4	.15	1.66	1.85	.51	1.66	1.47	1/2
EPMX66N-1	3/8	.25	1.77	1.96	.51	1.73	1.54	5/8
EPMX88N-1	1/2	.38	1.88	1.94	.66	1.72	1.66	3/4
EPMX1212N-1	3/4	.63	2.21	2.21	.84	1.98	1.98	1

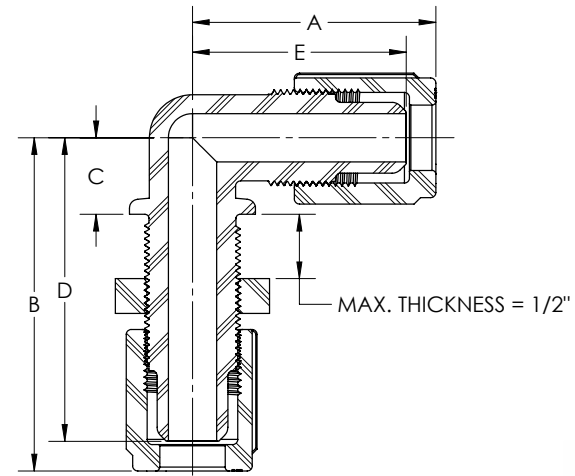

Union Elbow Reducer (Male Flare x Male Flare)								
PFA Part No.	PVDF Part No.	Tube O.D.	Tube O.D.	Orifice	A	B	C	D
UE64N-1	UE64	3/8	1/4	.15	1.76	1.53	1.47	1.66
UE84N-1	UE84	1/2	1/4	.15	1.87	1.65	1.47	1.66
UE86N-1	UE86	1/2	3/8	.25	1.87	1.65	1.53	1.76
UE124N-1		3/4	1/4	.15	2.22	1.99	1.47	1.66
UE126N-1		3/4	3/8	.25	2.22	1.99	1.53	1.76
UE128N-1	UE128	3/4	1/2	.38	2.22	1.99	1.65	1.87
UE168N-1		1	1/2	.38	2.70	2.43	1.81	2.03
UE1612N-1	UE1612	1	3/4	.63	2.70	2.43	1.99	2.22

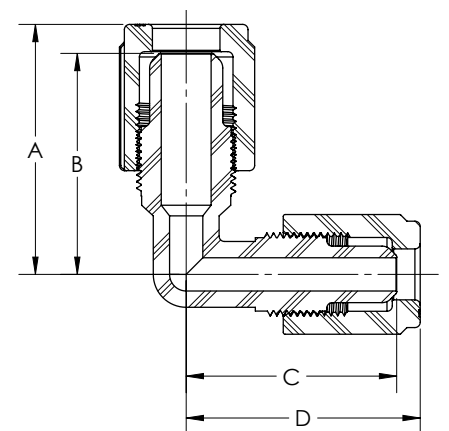

Union Elbow (TightFLARE™) (Male Flare x Female Flare) Patented							
PFA Part No.	Tube O.D.	TightFLARE	Orifice	A	B	C	D
UE44TN-1	1/4	1/4	.15	1.65	1.46	.87	1.64
UE46TN-1	1/4	3/8	.15	1.65	1.46	.96	1.73
UE48TN-1	1/4	1/2	.15	1.65	1.46	1.07	1.84
UE64TN-1	3/8	1/4	.15	1.76	1.53	1.41	1.64
UE66TN-1	3/8	3/8	.25	1.76	1.53	1.41	1.73
UE68TN-1	3/8	1/2	.25	1.76	1.53	1.41	1.84
UE612TN-1	3/8	3/4	.25	1.76	1.53	1.41	2.13
UE84TN-1	1/2	1/4	.15	1.87	1.65	1.42	1.64
UE86TN-1	1/2	3/8	.25	1.87	1.65	1.42	1.73
UE88TN-1	1/2	1/2	.38	1.87	1.65	1.42	1.84
UE812TN-1	1/2	3/4	.38	1.87	1.65	1.42	2.13
UE816TN-1	1/2	1	.38	2.03	1.81	1.42	2.74
UE126TN-1	3/4	3/8	.25	2.22	1.99	1.50	1.73
UE128TN-1	3/4	1/2	.38	2.22	1.99	1.50	1.84
UE1212TN-1	3/4	3/4	.63	2.22	1.99	1.50	2.13
UE1216TN-1	3/4	1	.63	2.22	1.99	1.50	2.74
UE1612TN-1	1	3/4	.63	2.70	2.43	1.86	2.13
UE1616TN-1	1	1	.88	2.70	2.43	1.86	2.74
UE2020TN-1	1-1/4	1-1/4	1.10	2.96	2.65	2.79	3.10

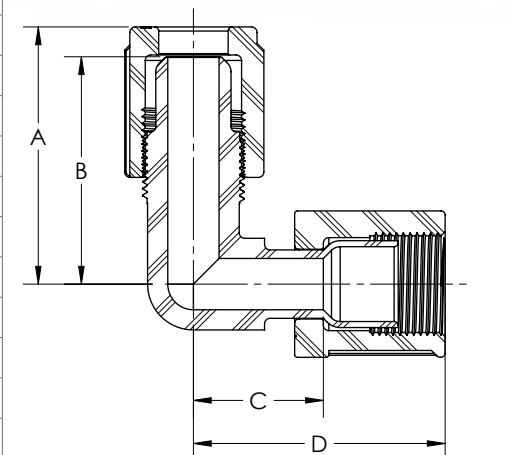



Union Elbow (TightFLARE™) (Female Flare x Female Flare) Patented				
PFA Part No.	TightFLARE	Orifice	A	B
UE4TN-1	1/4	.15	1.64	.87
UE6TN-1	3/8	.25	1.73	.88
UE8TN-1	1/2	.38	1.84	.94
UE12TN-1	3/4	.63	2.13	1.08
UE16TN-1	1	.88	2.74	1.40
UE20TN-1	1-1/4	1.10	3.10	1.80

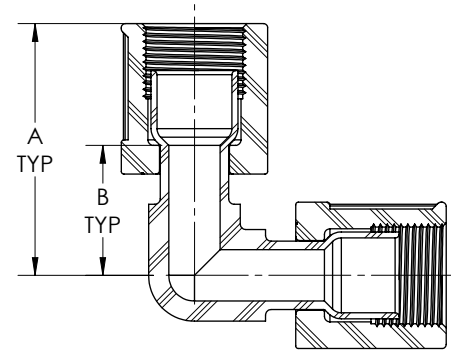

Union Elbow Reducer (TightFLARE™) (Female Flare x Female Flare) Patented							
PFA Part No.	TightFLARE	TightFLARE	Orifice	A	B	C	D
UE6T4TN-1	3/8	1/4	.15	1.73	.88	.87	1.64
UE8T4TN-1	1/2	1/4	.15	1.84	.90	.87	1.64
UE8T6TN-1	1/2	3/8	.25	1.84	.90	.88	1.73
UE12T8TN-1	3/4	1/2	.38	2.13	1.08	.94	1.84
UE16T12TN-1	1	3/4	.63	2.74	1.40	1.08	2.13

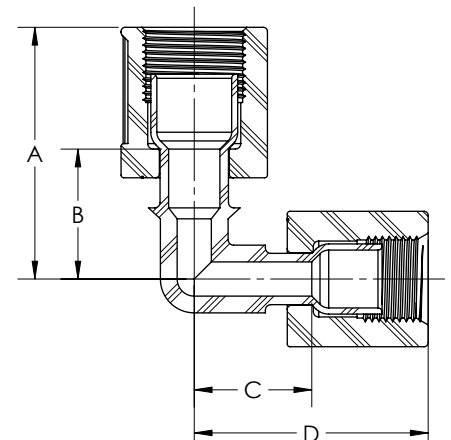

## Flow Coefficient (Cv) Data Comparison

- Fit-LINE's 1/4" Sweep Elbow is 133% more efficient than a 1/4" Standard 90° Elbow.
- Fit-LINE's 3/8" Sweep Elbow is 67% more efficient than a 3/8" Standard 90° Elbow.
- Fit-LINE's 1/2" Sweep Elbow is 38% more efficient than the competitor 1/2" Sweep Elbow and is 90% more efficient than a 1/2" Standard 90° Elbow.
- Fit-LINE's 3/4" Sweep Elbow is 62% more efficient than the competitor 3/4" Sweep Elbow and is 116% more efficient than a 3/4" Standard 90° Elbow.
- Fit-LINE's 1" Sweep Elbow is 69% more efficient than the competitor 1" Sweep Elbow and is 130% more efficient than a 1" Standard 90° Elbow.



Union Elbow Sweep (Male Flare x Male Flare) Patented				
PFA Part No.	Tube O.D.	Orifice	A	B
UES44N-1	1/4	.15	1.62	1.43
UES66N-1	3/8	.25	1.83	1.60
UES88N-1	1/2	.38	2.05	1.83
UES1212N-1	3/4	.63	2.33	2.10
UES1616N-1	1	.88	2.78	2.51

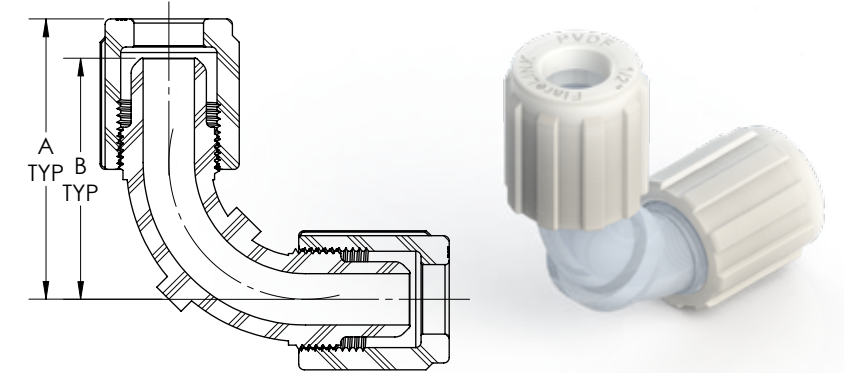

Union Elbow Sweep (TightFLARE™) (Male Flare x Female Flare) Patented						
PFA Part No.	Tube O.D. / TightFLARE	Orifice	A	B	C	D
UES44TN-1	1/4	.15	1.62	1.43	1.01	1.78
UES66TN-1	3/8	.25	1.83	1.60	1.12	1.97
UES88TN-1	1/2	.38	2.05	1.83	1.25	2.15
UES1212TN-1	3/4	.63	2.33	2.10	1.51	2.56
UES1616TN-1	1	.88	2.78	2.51	1.88	3.22

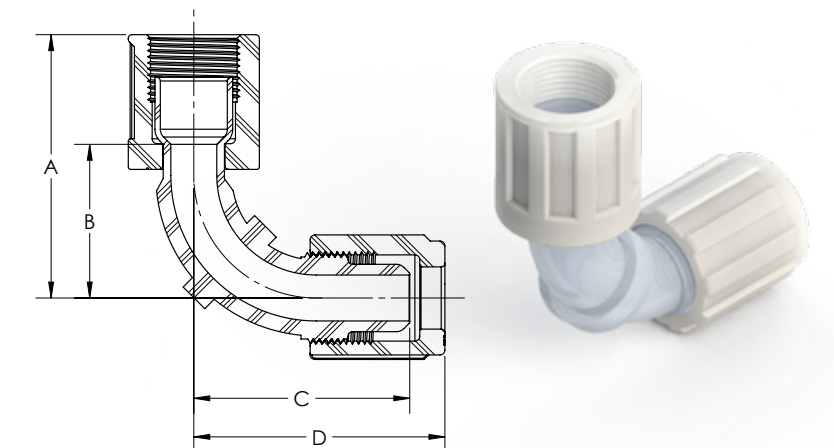



Union Elbow Sweep (TightFLARE™) (Female Flare x Female Flare) Patented				
PFA Part No.	TightFLARE	Orifice	A	B
UES4TN-1	1/4	.15	1.78	1.01
UES6TN-1	3/8	.25	1.97	1.12
UES8TN-1	1/2	.38	2.15	1.25
UES12TN-1	3/4	.63	2.56	1.51
UES16TN-1	1	.88	3.22	1.88

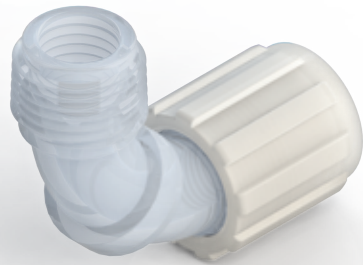
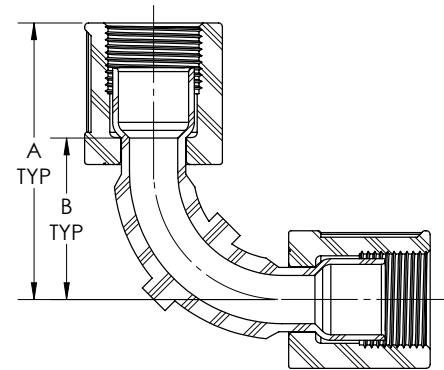

Male Elbow Sweep (Male Flare x MNPT) Patented					
PFA Part No.	Tube O.D. / MNPT	Orifice	A	B	C
MES4-4N-1	1/4	.15	1.62	1.43	1.20
MES6-6N-1	3/8	.25	1.83	1.60	1.32
MES8-8N-1	1/2	.38	2.05	1.83	1.55
MES12-12N-1	3/4	.63	2.33	2.10	1.76
MES16-16N-1	1	.88	2.78	2.51	2.26

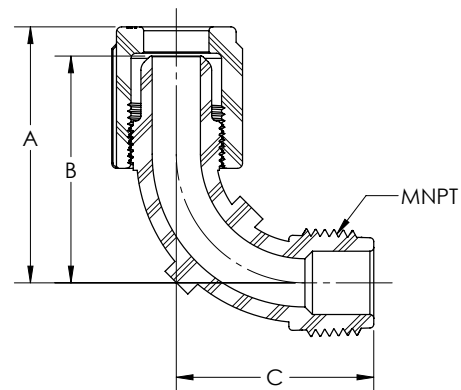

Male Elbow Sweep (TightFLARE™) (Female Flare x Male Flare) Patented					
PFA Part No.	TightFLARE / MNPT	Orifice	A	B	C
MES4T-4N-1	1/4	.15	1.78	1.01	1.20
MES6T-6N-1	3/8	.25	1.97	1.12	1.32
MES8T-8N-1	1/2	.38	2.15	1.25	1.55
MES12T-12N-1	3/4	.63	2.56	1.51	1.76
MES16T-16N-1	1	.88	3.22	1.88	2.26

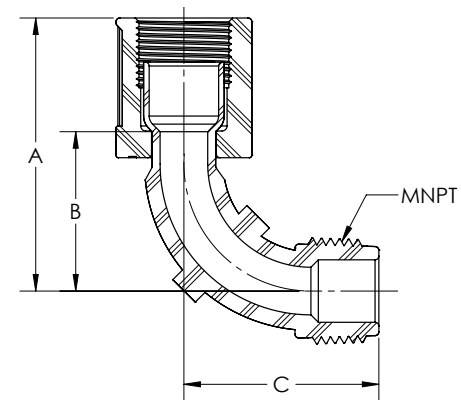

Union Tee (Male Flare x Male Flare x Male Flare)						
PFA Part No.	PVDF Part No.	Tube O.D.	Orifice	A	B	C
UT4N-1	UT4	1/4	.15	3.32	1.66	1.47
UT6N-1	UT6	3/8	.25	3.52	1.76	1.53
UT8N-1	UT8	1/2	.38	3.74	1.87	1.65
UT12N-1	UT12	3/4	.63	4.44	2.22	1.99
UT16N-1	UT16	1	.88	5.40	2.70	2.43
UT20N-1	UT20	1-1/4	1.10	5.92	2.96	2.65

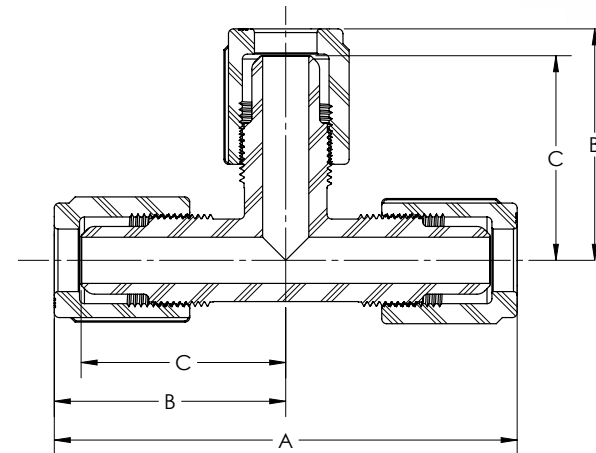

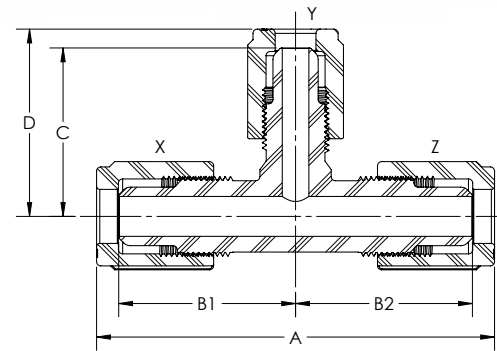

Union Tee Reducer (Male Flare x Male Flare x Male Flare)									
PFA Part No.	X	Y	Z	Orifice	A	B1	B2	C	D
UT4-6-4N-1	1/4	3/8	1/4	.15	3.32	1.47	1.47	1.53	1.76
UT4-8-4N-1	1/4	1/2	1/4	.15	3.32	1.47	1.47	1.65	1.87
UT6-4-4N-1	3/8	1/4	1/4	.15	3.42	1.53	1.47	1.47	1.66
UT6-4-6N-1	3/8	1/4	3/8	.15	3.52	1.53	1.53	1.47	1.66
UT6-6-4N-1	3/8	3/8	1/4	.15	3.42	1.53	1.47	1.53	1.76
UT6-8-6N-1	3/8	1/2	3/8	.25	3.52	1.53	1.53	1.65	1.87
UT6-12-6N-1	3/8	3/4	3/8	.25	3.52	1.53	1.53	1.98	2.23
UT8-4-4N-1	1/2	1/4	1/4	.15	3.53	1.65	1.47	1.47	1.66
UT8-4-6N-1	1/2	1/4	3/8	.15	3.63	1.65	1.53	1.47	1.66
UT8-4-8N-1	1/2	1/4	1/2	.15	3.74	1.65	1.65	1.47	1.66
UT8-6-6N-1	1/2	3/8	3/8	.25	3.63	1.65	1.53	1.53	1.76
UT8-6-8N-1	1/2	3/8	1/2	.25	3.74	1.65	1.65	1.53	1.76
UT8-8-4N-1	1/2	1/2	1/4	.15	3.53	1.65	1.47	1.65	1.87
UT8-8-6N-1	1/2	1/2	3/8	.38	3.63	1.65	1.53	1.65	1.87
UT8-12-8N-1	1/2	3/4	1/2	.38	3.72	1.66	1.65	1.99	2.22
UT12-4-12N-1	3/4	1/4	3/4	.15	4.44	1.99	1.99	1.47	1.66
UT12-6-12N-1	3/4	3/8	3/4	.25	4.44	1.99	1.99	1.53	1.76
UT12-8-8N-1	3/4	1/2	1/2	.38	4.09	1.99	1.65	1.65	1.87
UT12-8-12N-1	3/4	1/2	3/4	.38	4.44	1.99	1.99	1.65	1.87
UT12-12-4N-1	3/4	3/4	1/4	.15	3.90	1.99	1.47	1.99	2.24
UT12-12-6N-1	3/4	3/4	3/8	.25	3.98	1.99	1.53	1.99	2.22
UT12-12-8N-1	3/4	3/4	1/2	.38	4.09	1.99	1.65	1.99	2.22
UT12-16-12N-1	3/4	1	3/4	.63	4.44	1.99	1.99	2.43	2.70
UT16-4-16N-1	1	1/4	1	.15	5.40	2.43	2.43	1.83	2.02
UT16-6-16N-1	1	3/8	1	.25	5.40	2.43	2.43	1.90	2.13
UT16-8-8N-1	1	1/2	1/2	.38	4.66	2.52	1.66	1.66	1.87
UT16-8-16N-1	1	1/2	1	.38	5.40	2.43	2.43	2.04	2.26
UT16-12-12N-1	1	3/4	3/4	.63	5.40	2.43	1.99	1.99	2.22
UT16-12-16N-1	1	3/4	1	.63	4.92	2.43	2.43	1.99	2.22
UT16-16-4N-1	1	1	1/4	.15	4.69	2.41	1.83	2.41	2.69
UT16-16-6N-1	1	1	3/8	.25	4.77	2.41	1.90	2.41	2.69
UT16-16-8N-1	1	1	1/2	.38	4.92	2.43	2.00	2.43	2.70
UT16-16-12N-1	1	1	3/4	.63	4.92	2.43	1.99	2.43	2.70
UT20-16-20N-1	1-1/4	1	1-1/4	.88	5.90	2.65	2.65	2.41	2.69

Union Tee (TightFLARE™) Branch (Male Flare x Female Flare x Male Flare) Patented									
PFA Part No.	X	Y	Z	Orifice	A	B1	B2	C	D
UT4-4T-4N-1	1/4	1/4	1/4	.15	3.32	1.47	1.47	.87	1.64
UT4-6T-4N-1	1/4	3/8	1/4	.15	3.32	1.47	1.47	.88	1.73
UT6-4T-6N-1	3/8	1/4	3/8	.15	3.52	1.53	1.53	.87	1.64
UT6-6T-4N-1	3/8	3/8	1/4	.15	3.42	1.53	.89	.88	1.73
UT6-6T-6N-1	3/8	3/8	3/8	.25	3.52	1.53	1.53	.88	1.73
UT6-8T-6N-1	3/8	1/2	3/8	.25	3.52	1.53	1.53	.94	1.84
UT8-4T-8N-1	1/2	1/4	1/2	.15	3.74	1.65	1.65	.87	1.64
UT8-6T-8N-1	1/2	3/8	1/2	.25	3.74	1.65	1.65	.88	1.73
UT8-8T-4N-1	1/2	1/2	1/4	.15	3.53	1.65	1.47	.94	1.84
UT8-8T-6N-1	1/2	1/2	3/8	.25	3.63	1.65	1.53	.94	1.84
UT8-8T-8N-1	1/2	1/2	1/2	.38	3.74	1.65	1.65	.94	1.84
UT12-4T-12N-1	3/4	1/4	3/4	.15	4.44	1.99	1.99	.87	1.64
UT12-6T-12N-1	3/4	3/8	3/4	.25	4.44	1.99	1.99	.88	1.73
UT12-8T-8N-1	3/4	1/2	1/2	.38	4.09	1.99	1.65	.94	1.84
UT12-8T-12N-1	3/4	1/2	3/4	.38	4.44	1.99	1.99	1.07	1.97
UT12-12T-6N-1	3/4	3/4	3/8	.25	3.98	1.99	1.53	1.08	2.13
UT12-12T-8N-1	3/4	3/4	1/2	.38	4.09	1.99	1.65	1.08	2.13
UT12-12T-12N-1	3/4	3/4	3/4	.63	4.44	1.99	1.99	1.08	2.13
UT12-16T-12N-1	3/4	1	3/4	.63	4.44	1.99	1.99	1.40	2.74
UT16-8T-16N-1	1	1/2	1	.38	5.40	2.43	2.43	1.19	2.09
UT16-12T-12N-1	1	3/4	3/4	.63	4.92	2.43	1.99	1.08	2.13
UT16-12T-16N-1	1	3/4	1	.63	5.40	2.43	2.43	1.18	2.23
UT16-16T-12N-1	1	1	3/4	.63	4.95	2.43	1.99	1.40	2.74
UT16-16T-16N-1	1	1	1	.88	5.40	2.43	2.43	1.40	2.74
UT20-20T-20N-1	1-1/4	1-1/4	1-1/4	1.10	5.92	2.65	2.65	1.80	3.10

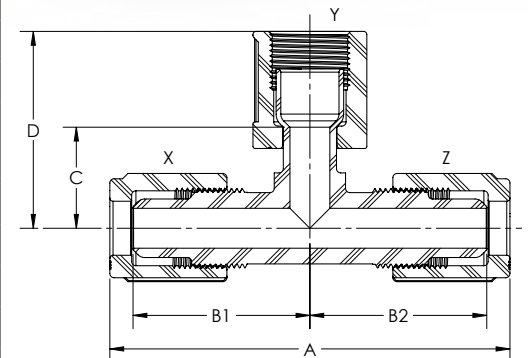



Union Tee (TightFLARE™) Run  
(Male Flare x Male Flare x Female Flare)  
Patented

PFA Part No.	X	Y	Z	Orifice	A	B1	B2	C	D
UT4-4-4TN-1	1/4	1/4	1/4	.15	3.30	1.47	.87	1.47	1.66
UT4-8-8TN-1	1/4	1/2	1/2	.15	3.50	1.47	.94	1.65	1.87
UT6-4-6TN-1	3/8	1/4	3/8	.15	3.49	1.53	.88	1.47	1.66
UT6-6-6TN-1	3/8	3/8	3/8	.25	3.49	1.53	.88	1.53	1.76
UT6-6-8TN-1	3/8	3/8	1/2	.25	3.60	1.53	.94	1.53	1.76
UT6-8-8TN-1	3/8	1/2	1/2	.25	3.60	1.53	.94	1.65	1.87
UT6-12-12TN-1	3/8	3/4	3/4	.25	3.89	1.53	1.08	1.99	2.22
UT6-16-16TN-1	3/8	1	1	.25	4.82	1.90	1.40	2.41	2.69
UT8-4-8TN-1	1/2	1/4	1/2	.15	3.71	1.65	.94	1.47	1.66
UT8-6-6TN-1	1/2	3/8	3/8	.25	3.60	1.65	.88	1.53	1.76
UT8-6-8TN-1	1/2	3/8	1/2	.25	3.71	1.65	.94	1.53	1.76
UT8-8-6TN-1	1/2	1/2	3/8	.25	3.60	1.65	.88	1.65	1.87
UT8-8-8TN-1	1/2	1/2	1/2	.38	3.71	1.65	.94	1.65	1.87
UT8-8-12TN-1	1/2	1/2	3/4	.38	4.00	1.65	1.08	1.65	1.87
UT12-4-12TN-1	3/4	1/4	3/4	.15	4.35	1.99	1.08	1.47	1.66
UT12-6-12TN-1	3/4	3/8	3/4	.25	4.35	1.99	1.08	1.53	1.76
UT12-8-12TN-1	3/4	1/2	3/4	.38	4.35	1.99	1.08	1.65	1.87
UT12-12-8TN-1	3/4	3/4	1/2	.38	4.06	1.99	.94	1.99	2.22
UT12-12-12TN-1	3/4	3/4	3/4	.63	4.35	1.99	1.08	1.99	2.22
UT16-4-16TN-1	1	1/4	1	.15	5.44	2.43	1.40	1.83	2.02
UT16-6-16TN-1	1	3/8	1	.25	5.44	2.43	1.40	1.90	2.13
UT16-8-16TN-1	1	1/2	1	.38	5.44	2.43	1.40	2.04	2.26
UT16-12-16TN-1	1	3/4	1	.63	5.44	2.43	1.40	1.99	2.22
UT16-16-12TN-1	1	1	3/4	.63	4.94	2.43	1.40	2.43	2.70
UT16-16-16TN-1	1	1	1	.88	5.44	2.43	1.40	2.43	2.70
UT20-20-20TN-1	1-1/4	1-1/4	1-1/4	1.10	6.06	2.65	1.80	2.65	2.96

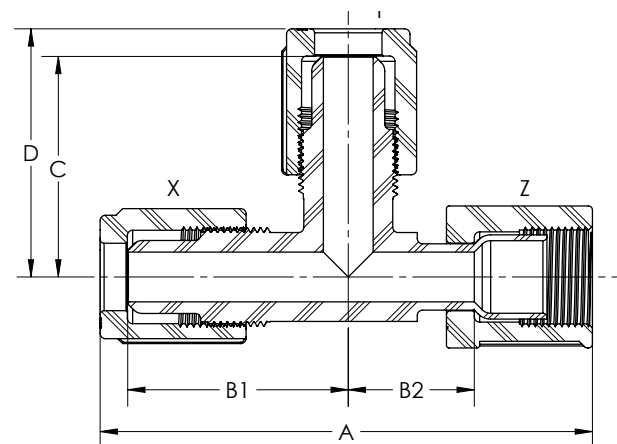

Union Tee (TightFLARE™) Branch, Run  
(Male Flare x Female Flare x Female Flare)  
Patented

PFA Part No.	X	Y	Z	Orifice	A	B1	B2	C	D
UT4-4T-4TN-1	1/4	1/4	1/4	.15	3.30	1.47	.77	.87	1.64
UT6-4T-6TN-1	3/8	1/4	3/8	.15	3.49	1.53	.88	.87	1.64
UT6-6T-6TN-1	3/8	3/8	3/8	.25	3.49	1.53	.88	.88	1.73
UT6-8T-8TN-1	3/8	1/2	1/2	.25	3.60	1.53	.94	.94	1.84
UT6-12T-12TN-1	3/8	3/4	3/4	.25	3.89	1.53	1.08	1.08	2.13
UT8-6T-6TN-1	1/2	3/8	3/8	.25	3.60	1.65	.88	.88	1.73
UT8-6T-8TN-1	1/2	3/8	1/2	.25	3.71	1.65	.94	.88	1.73
UT8-8T-8TN-1	1/2	1/2	1/2	.38	3.71	1.65	.94	.94	1.84
UT8-8T-12TN-1	1/2	1/2	3/4	.38	4.00	1.65	1.08	.94	1.84
UT8-12T-12TN-1	1/2	3/4	3/4	.38	4.00	1.65	1.08	1.08	2.13
UT12-8T-8TN-1	3/4	1/2	1/2	.38	4.06	1.99	.94	.94	1.84
UT12-8T-12TN-1	3/4	1/2	3/4	.38	4.35	1.99	1.08	.94	1.84
UT12-12T-8TN-1	3/4	3/4	1/2	.38	4.06	1.99	.94	1.08	2.13
UT12-12T-12TN-1	3/4	3/4	3/4	.63	4.35	1.99	1.08	1.08	2.13
UT16-8T-16TN-3	1	1/2	1	.38	5.44	2.43	1.40	1.19	2.09
UT16-12T-12TN-1	1	3/4	3/4	.63	4.83	2.43	1.08	1.08	2.13
UT16-12T-16TN-1	1	3/4	1	.63	5.44	2.43	1.40	1.08	2.13
UT16-16T-12TN-1	1	1	3/4	.63	4.94	2.43	1.19	1.40	2.74
UT16-16T-16TN-1	1	1	1	.88	5.44	2.43	1.40	1.40	2.74
UT20-16T-20TN-1	1-1/4	1	1-1/4	.88	6.06	2.65	1.80	1.25	2.59
UT20-20T-20TN-1	1-1/4	1-1/4	1-1/4	1.10	6.06	2.65	1.80	1.80	3.10

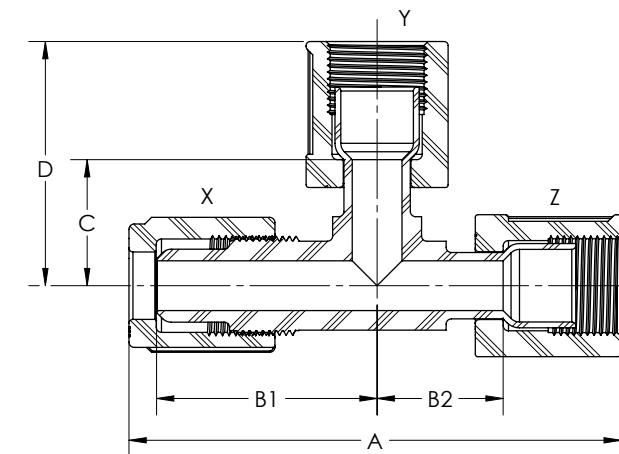





Union Tee (TightFLARE™) Run, Run  
(Female Flare x Male Flare x Female Flare)  
Patented

PFA Part No.	X	Y	Z	Orifice	A	B1	B2	C	D
UT4T-4-4TN-1	1/4	1/4	1/4	.15	3.28	.87	.87	1.47	1.66
UT4T-6-4TN-1	1/4	3/8	1/4	.15	3.28	.87	.87	1.53	1.76
UT6T-4-6TN-1	3/8	1/4	3/8	.15	3.46	.88	.88	1.47	1.66
UT6T-6-6TN-1	3/8	3/8	3/8	.25	3.46	.88	.88	1.53	1.76
UT6T-8-6TN-1	3/8	1/2	3/8	.25	3.46	.88	.88	1.65	1.87
UT8T-4-8TN-1	1/2	1/4	1/2	.15	3.68	.94	.94	1.47	1.66
UT8T-6-6TN-1	1/2	3/8	3/8	.25	3.57	.94	.88	1.53	1.76
UT8T-8-4TN-1	1/2	1/2	1/4	.15	3.48	.94	.87	1.65	1.87
UT8T-8-6TN-1	1/2	1/2	3/8	.25	3.57	.94	.88	1.65	1.87
UT8T-8-8TN-1	1/2	1/2	1/2	.38	3.68	.94	.94	1.65	1.87
UT8T-12-8TN-1	1/2	3/4	1/2	.38	3.68	.94	.94	1.99	2.22
UT12T-4-12TN-1	3/4	1/4	3/4	.15	4.26	1.08	1.08	1.47	1.66
UT12T-6-12TN-1	3/4	3/8	3/4	.25	4.26	1.08	1.08	1.53	1.76
UT12T-8-8TN-1	3/4	1/2	1/2	.38	4.26	1.08	1.08	1.65	1.87
UT12T-8-12TN-1	3/4	1/2	3/4	.38	4.26	1.08	1.08	1.65	1.87
UT12T-12-12TN-1	3/4	3/4	3/4	.63	4.26	1.08	1.08	1.99	2.22
UT12T-16-12TN-1	3/4	1	3/4	.63	4.26	1.08	1.08	2.43	2.70
UT16T-6-16TN-1	1	3/8	1	.25	5.48	1.40	1.40	1.90	2.13
UT16T-8-16TN-1	1	1/2	1	.38	5.48	1.40	1.40	2.04	2.26
UT16T-12-16TN-1	1	3/4	1	.63	5.48	1.40	1.40	1.98	2.21
UT16T-16-16TN-1	1	1	1	.88	5.48	1.40	1.40	2.43	2.70
UT20T-20-20TN-1	1-1/4	1-1/4	1-1/4	1.10	6.20	1.80	1.80	2.65	2.96

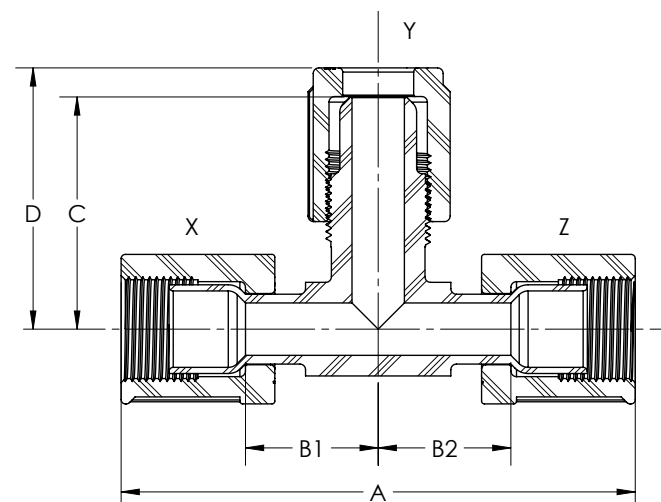

Union Tee (TightFLARE™) All  
(Female Flare x Female Flare x Female Flare)  
Patented

PFA Part No.	X	Y	Z	Orifice	A	B1	B2	C	D
UT4TN-1	1/4	1/4	1/4	.15	3.28	.87	.87	.87	1.64
UT4T-6T-4TN-1	1/4	3/8	1/4	.15	3.28	.87	.87	.88	1.73
UT6TN-1	3/8	3/8	3/8	.25	3.46	.88	.88	.88	1.73
UT6T-8T-4TN-1	3/8	1/2	1/4	.15	3.37	.88	.87	.94	1.84
UT8TN-1	1/2	1/2	1/2	.38	3.68	.94	.94	.94	1.84
UT8T-6T-6TN-1	1/2	3/8	3/8	.25	3.57	.94	.88	.88	1.73
UT8T-8T-4TN-1	1/2	1/2	1/4	.15	3.48	.94	.87	.94	1.84
UT8T-12T-8TN-1	1/2	3/4	1/2	.38	3.68	.94	.94	1.08	2.13
UT12TN-1	3/4	3/4	3/4	.63	4.26	1.08	1.08	1.08	2.13
UT12T-6T-12TN-1	3/4	3/8	3/4	.25	4.26	1.08	1.08	.88	1.73
UT12T-8T-12TN-1	3/4	1/2	3/4	.38	4.23	1.08	1.08	.94	1.84
UT12T-12T-8TN-1	3/4	3/4	1/2	.38	3.97	1.08	.94	1.08	2.13
UT16T-12T-16TN-1	1	3/4	1	.63	5.48	1.40	1.40	1.08	2.13
UT16TN-1	1	1	1	.88	5.48	1.40	1.40	1.40	2.74
UT20TN-1	1-1/4	1-1/4	1-1/4	1.10	6.20	1.80	1.80	1.80	3.10
UT20T-16T-20TN-1	1-1/4	1	1-1/4	.88	6.20	1.80	1.80	1.25	2.59

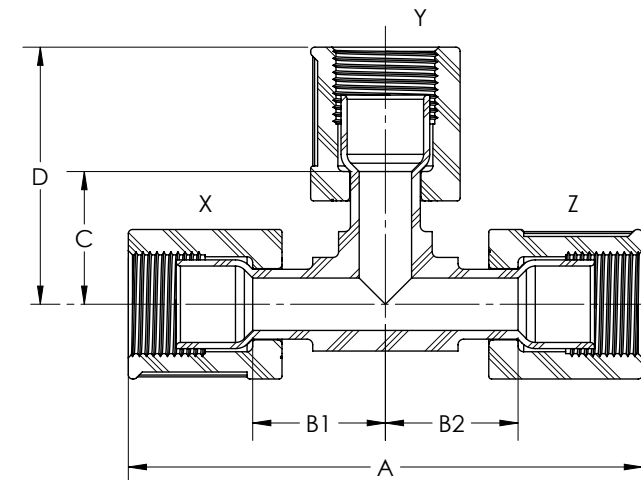



Male Run Tee (Male Flare x Male Flare x MNPT)								
PFA Part No.	PVDF Part No.	Tube O.D.	Tube O.D.	MNPT Size	Orifice	A	B	C
MRT44-2N-1	MRT44-2	1/4	1/4	1/8	.15	2.72	1.49	1.68
MRT44-4N-1	MRT44-4	1/4	1/4	1/4	.15	2.72	1.49	1.68
MRT44-6N-1		1/4	1/4	3/8	.15	2.72	1.49	1.68
MRT66-2N-1		3/8	3/8	1/8	.17	2.83	1.53	1.76
MRT66-4N-1		3/8	3/8	1/4	.25	2.83	1.53	1.76
MRT66-6N-1	MRT66-6	3/8	3/8	3/8	.25	2.83	1.53	1.76
MRT66-8N-1		3/8	3/8	1/2	.25	2.83	1.53	1.76
MRT88-6N-1		1/2	1/2	3/8	.38	2.96	1.65	1.87
MRT88-8N-1	MRT88-8	1/2	1/2	1/2	.38	3.04	1.65	1.87
MRT1212-6N-1		3/4	3/4	3/8	.38	3.45	1.99	2.22
MRT1212-8N-1		3/4	3/4	1/2	.49	3.56	1.99	2.22
MRT1212-12N-1	MRT1212-12	3/4	3/4	3/4	.63	3.59	1.99	2.22
MRT1616-12N-1		1	1	3/4	.63	4.34	2.43	2.70
MRT1616-16N-1	MRT1616-16	1	1	1	.88	4.50	2.43	2.70

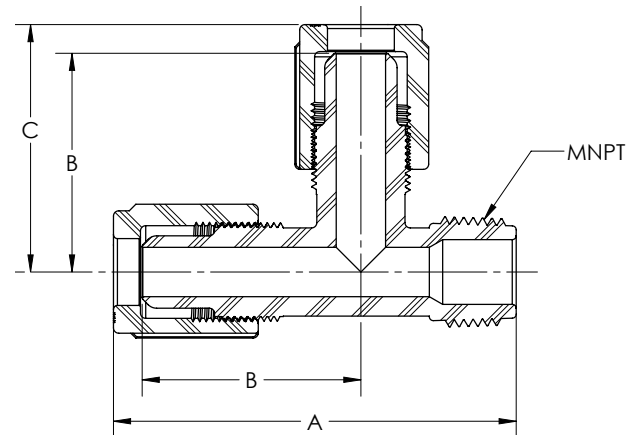

Male Branch Tee (TightFLARE™) (Female Flare x MNPT x Female Flare) Patented						
PFA Part No.	TightFLARE	MNPT Size	Orifice	A	B	C
MBT12T12T-8N-1	3/4	1/2	.49	4.24	1.07	1.35
MBT16T16T-8N-1	1	1/2	.49	5.48	1.40	1.63
MBT16T16T-16N-1	1	1	.88	5.48	1.40	1.81

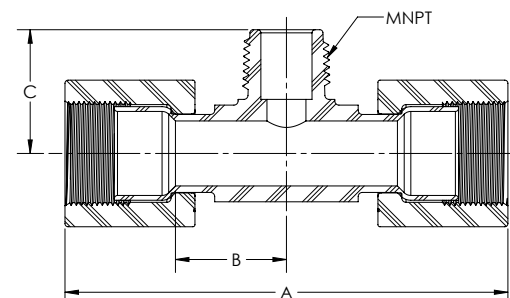

Male Branch Tee (Male Flare x MNPT x Male Flare)									
PFA Part No.	PVDF Part No.	Tube O.D.	Tube O.D.	MNPT Size	Orifice	A	B1	B2	C
MBT44-2N-1		1/4	1/4	1/8	.15	3.32	1.47	1.47	1.07
MBT44-4N-1	MBT44-4	1/4	1/4	1/4	.15	3.32	1.47	1.47	1.07
MBT44-8N-1		1/4	1/4	1/2	.15	3.32	1.47	1.47	1.17
MBT64-4N-1		3/8	1/4	1/4	.15	3.42	1.53	1.47	1.07
MBT64-6N-1		3/8	1/4	3/8	.15	3.52	1.53	1.57	1.07
MBT66-2N-1		3/8	3/8	1/8	.25	3.52	1.53	1.53	1.07
MBT66-4N-1	MBT66-4	3/8	3/8	1/4	.25	3.52	1.53	1.53	1.07
MBT66-6N-1	MBT66-6	3/8	3/8	3/8	.25	3.52	1.53	1.53	1.07
MBT66-8N-1		3/8	3/8	1/2	.25	3.52	1.53	1.53	1.17
MBT84-8N-1		1/2	1/4	1/2	.15	3.53	1.65	1.47	1.17
MBT86-6N-1		1/2	3/8	3/8	.25	3.64	1.65	1.54	1.08
MBT86-8N-1		1/2	3/8	1/2	.25	3.64	1.65	1.54	1.17
MBT88-4N-1		1/2	1/2	1/4	.25	3.74	1.65	1.65	1.07
MBT88-6N-1		1/2	1/2	3/8	.38	3.74	1.65	1.65	1.08
MBT88-8N-1	MBT88-8	1/2	1/2	1/2	.38	3.74	1.65	1.65	1.17
MBT88-12N-1		1/2	1/2	3/4	.38	3.74	1.65	1.65	1.35
MBT1212-4N-1		3/4	3/4	1/4	.25	4.44	1.99	1.99	1.27
MBT1212-8N-1		3/4	3/4	1/2	.51	4.44	1.99	1.99	1.35
MBT1212-12N-1	MBT1212-12	3/4	3/4	3/4	.63	4.44	1.99	1.99	1.35
MBT1616-4N-1		1	1	1/4	.25	5.40	2.43	2.43	1.57
MBT1616-6N-1		1	1	3/8	.38	5.40	2.43	2.43	1.54
MBT1616-8N-1		1	1	1/2	.51	5.40	2.43	2.43	1.63
MBT1616-12N-1		1	1	3/4	.69	5.40	2.43	2.43	1.63
MBT1616-16N-1	MBT1616-16	1	1	1	.88	5.40	2.43	2.43	1.81
MBT2020-8N-1		1-1/4	1-1/4	1/2	.51	5.92	2.65	2.65	2.00

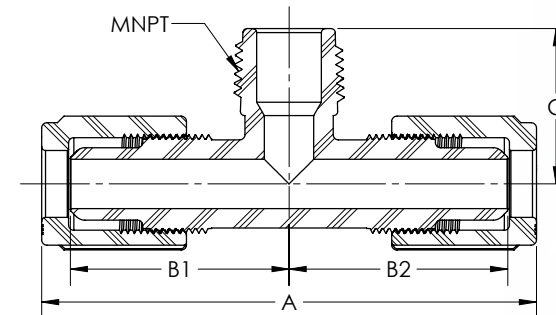



Female Run Tee (Male Flare x Male Flare x FNPT)						
PFA Part No.	Tube O.D.	Tube O.D.	FNPT Size	Orifice	A	B
FRT1212-12N-1	3/4	3/4	3/4	.63	3.75	1.99

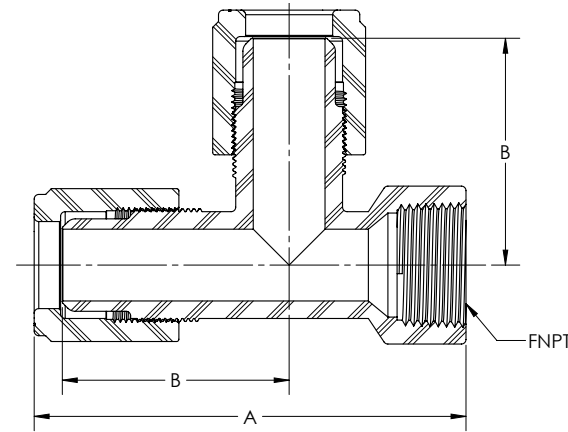

Female Branch Tee (Male Flare x FNPT x Male Flare)						
PFA Part No.	Tube O.D.	NPT	Orifice	A	B	C
FBT88-4N-1	1/2	1/4	.38	3.72	1.66	1.11
FBT1212-4N-1	3/4	1/4	.38	4.44	1.99	1.43
FBT1212-12N-1	3/4	3/4	.63	4.44	1.99	1.53
FBT1616-4N-1	1	1/4	.38	5.40	2.43	1.43
FBT1616-8N-1	1	1/2	.51	5.40	2.43	1.38

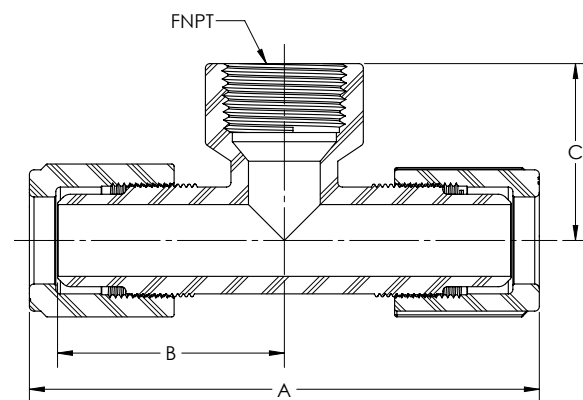

Flare Plug and Nut (Male Flare)							
PFA Flare Plug Part No.	Tube O.D.	A	Hex	PFA Flare Plug & Nut Part No.	A	B	Hex
FP4	1/4	1.25	5/8	FP4N-1	1.47	.70	5/8
FP6	3/8	1.34	13/16	FP6N-1	1.57	.92	13/16
FP8	1/2	1.43	15/16	FP8N-1	1.67	1.04	15/16
FP12	3/4	1.58	1-3/16	FP12N-1	1.79	1.32	1-3/16
FP16	1	1.75	1-7/16	FP16N-1	2.01	1.60	1-7/16
FP20	1-1/4	2.13	1-3/4	FP20N-1	2.63	1.96	1-3/4

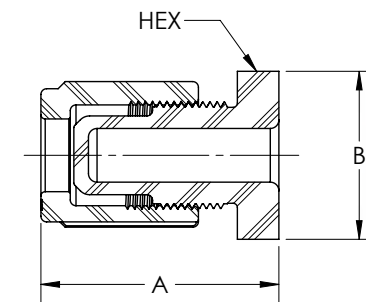
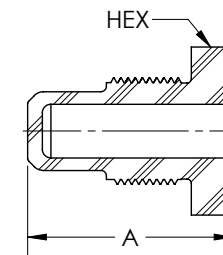

Flare Cap (Female Flare)			
PFA Part No.	Flare Size	A	B
FCAP4	1/4	.71	.39
FCAP6	3/8	.84	.53
FCAP8	1/2	.92	.68
FCAP12	3/4	1.04	.93
FCAP16	1	1.20	1.26
FCAP20	1-1/4	1.77	1.57

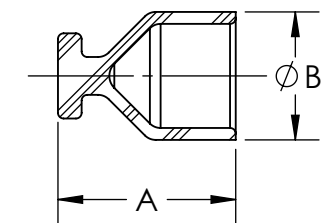

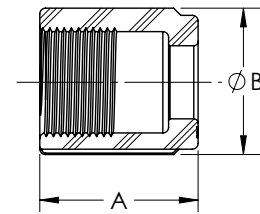

Flare Nut PFA			
PFA Part No.	Tube O.D.	A	B
N4-3	1/4	1.02	.84
N6-3	3/8	1.03	.99
N8-3	1/2	1.12	1.07
N12-3	3/4	1.27	1.41
N16-3	1	1.51	1.85
N20-3	1-1/4	1.86	2.32

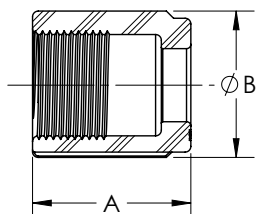

Flare Nut PVDF			
PVDF Part No.	Tube O.D.	A	B
N4-1	1/4	1.00	.73
N6-1	3/8	1.01	.85
N8-1	1/2	1.09	1.00
N12-1	3/4	1.25	1.32
N16-1	1	1.49	1.76
N20-1	1-1/4	1.83	2.20

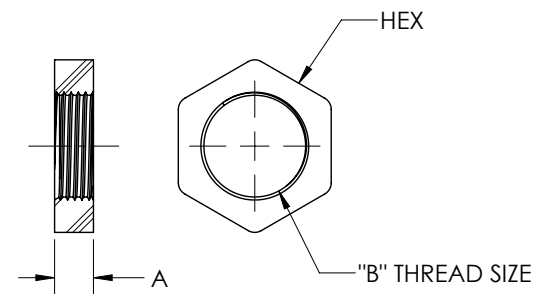
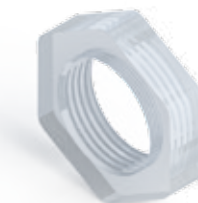

Panel Mount Nut (Half Nut) PFA			
PFA Part No.	Hex	A	B
PMN4-3	13/16	.29	1/2-20 UNF
PMN6-3	1	.29	5/8-20 UN
PMN8-3	1-1/8	.30	3/4-20 UNEF
PMN12-3	1-3/8	.32	1-20 UNEF
PMN16-3	1-7/8	.34	1-7/16-12 UN

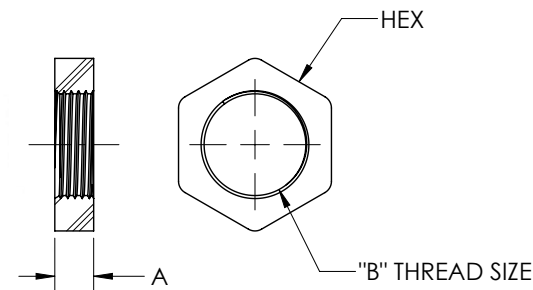
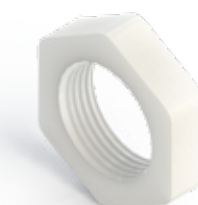

Panel Mount Nut (Half Nut) PVDF			
PVDF Part No.	Hex	A	B
PMN4-1	3/4	.26	1/2-20 UNF
PMN6-1	15/16	.26	5/8-20 UN
PMN8-1	1-1/16	.27	3/4-20 UNEF
PMN12-1	1-5/16	.28	1-20 UNEF
PMN16-1	1-3/4	.27	1-7/16-12 UN

Weld Straight Connector (Pipe x Male Flare)									
PFA Part No.	Pipe Size	Tube Size	Orifice	A	B	C	D	E	Hex
WSC4P-4N-1	1/4	1/4	.15	2.02	.54	.35	.55	1.83	5/8
WSC4P-6N-1	1/4	3/8	.25	2.12	.54	.35	.55	1.89	13/16
WSC4P-8N-1	1/4	1/2	.35	2.21	.54	.35	.55	1.99	13/16
WSC8P-4N-1	1/2	1/4	.15	3.15	.84	.61	1.50	2.96	1
WSC8P-6N-1	1/2	3/8	.25	3.26	.84	.61	1.50	3.03	1
WSC8P-8N-1	1/2	1/2	.38	3.36	.84	.61	1.50	3.14	1
WSC8P-12N-1	1/2	3/4	.61	3.50	.84	.61	1.50	3.27	1-3/16
WSC12P-4N-1	3/4	1/4	.15	3.15	1.05	.81	1.50	2.96	1-3/16
WSC12P-6N-1	3/4	3/8	.25	3.26	1.05	.81	1.50	3.03	1-3/16
WSC12P-8N-1	3/4	1/2	.38	3.36	1.05	.81	1.50	3.14	1-3/16
WSC12P-12N-1	3/4	3/4	.63	3.50	1.05	.81	1.50	3.27	1-3/16
WSC12P-16N-1	3/4	1	.81	3.71	1.05	.81	1.50	3.44	1-7/16
WSC16P-8N-1	1	1/2	.38	2.63	1.32	1.05	1.50	2.41	1-7/16
WSC16P-12N-1	1	3/4	.63	3.50	1.32	1.03	1.50	3.27	1-7/16
WSC16P-16N-1	1	1	.88	3.71	1.32	1.03	1.50	3.44	1-7/16

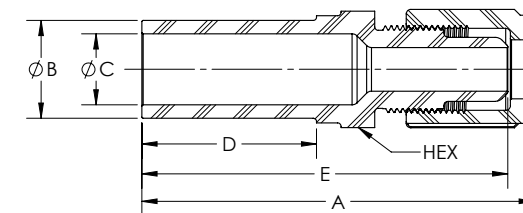

Weld Straight Connector (TightFLARE™) (Pipe x Female Flare) Patented								
PFA Part No.	Pipe Size	TightFLARE	Orifice	A	B	C	D	E
WSC4P-4TN-1	1/4	1/4	.15	2.17	.54	.35	.55	1.40
WSC4P-6TN-1	1/4	3/8	.25	2.21	.54	.35	.55	1.36
WSC8P-6TN-1	1/2	3/8	.25	3.38	.84	.61	1.50	2.53
WSC8P-8TN-1	1/2	1/2	.38	3.42	.84	.61	1.50	2.52
WSC8P-12TN-1	1/2	3/4	.61	3.58	.84	.61	1.50	2.53
WSC12P-8TN-1	3/4	1/2	.38	3.42	1.05	.81	1.50	2.52
WSC12P-12TN-1	3/4	3/4	.63	3.58	1.05	.81	1.50	2.53
WSC12P-16TN-1	3/4	1	.81	4.02	1.05	.81	1.50	2.68
WSC16P-8TN-1	1	1/2	.38	3.42	1.32	1.03	1.50	2.52
WSC16P-12TN-1	1	3/4	.63	3.58	1.32	1.03	1.50	2.53
WSC16P-16TN-1	1	1	.88	4.02	1.32	1.03	1.50	2.68
WSC16P-20TN-1	1	1-1/4	1.03	4.44	1.32	1.03	1.50	3.14

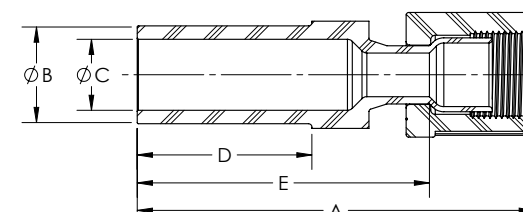

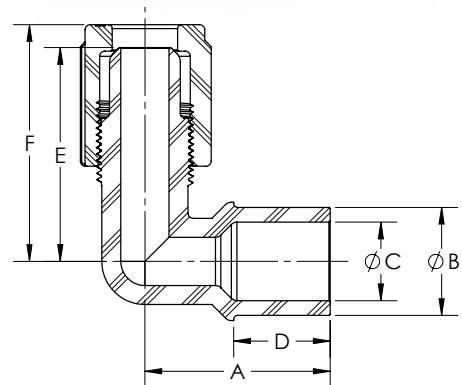

Weld Elbow Connector (Pipe x Male Flare)									
PFA Part No.	Pipe Size	Tube Size	Orifice	A	B	C	D	E	F
WEC4P-4N-1	1/4	1/4	.15	1.27	.54	.35	.75	1.47	1.66
WEC4P-6N-1	1/4	3/8	.25	1.27	.54	.35	.75	1.53	1.76
WEC8P-4N-1	1/2	1/4	.15	1.44	.84	.61	.75	1.47	1.66
WEC8P-6N-1	1/2	3/8	.25	1.44	.84	.61	.75	1.53	1.76
WEC8P-8N-1	1/2	1/2	.38	1.44	.84	.61	.75	1.65	1.87
WEC8P-12N-1	1/2	3/4	.61	1.50	.84	.61	.79	1.99	2.22
WEC12P-4N-1	3/4	1/4	.15	1.71	1.05	.81	.84	1.47	1.66
WEC12P-8N-1	3/4	1/2	.38	1.71	1.05	.81	.84	1.65	1.87
WEC12P-12N-1	3/4	3/4	.63	1.71	1.05	.81	.84	1.99	2.22
WEC12P-16N-1	3/4	1	.63	1.71	1.05	.81	1.05	2.43	2.70
WEC16P-8N-1	1	1/2	.38	1.72	1.32	1.03	.75	1.82	1.87
WEC16P-12N-1	1	3/4	.63	1.72	1.32	1.03	.75	1.99	2.22
WEC16P-16N-1	1	1	.88	1.72	1.32	1.03	.75	2.43	2.70

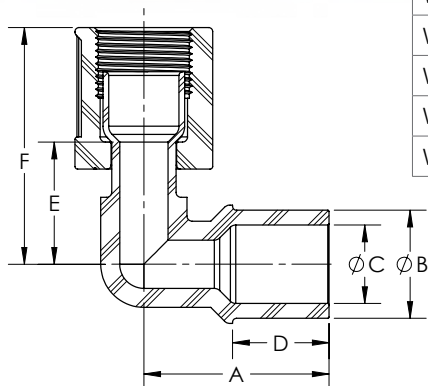

Weld Elbow Connector (TightFLARE™) (Pipe x Female Flare) Patented									
PFA Part No.	Pipe Size	TightFLARE	Orifice	A	B	C	D	E	F
WEC4P-4TN-1	1/4	1/4	.15	1.27	.54	.35	.75	.87	1.64
WEC4P-6TN-1	1/4	3/8	.25	1.27	.54	.35	.75	.88	1.73
WEC8P-4TN-1	1/2	1/4	.15	1.44	.84	.61	.75	.87	1.64
WEC8P-6TN-1	1/2	3/8	.25	1.44	.84	.61	.75	.88	1.73
WEC8P-8TN-1	1/2	1/2	.38	1.44	.84	.61	.75	.94	1.84
WEC8P-12TN-1	1/2	3/4	.61	1.50	.84	.61	.79	1.08	2.13
WEC12P-8TN-1	3/4	1/2	.38	1.71	1.05	.81	.84	.94	1.84
WEC12P-12TN-1	3/4	3/4	.63	1.71	1.05	.81	.84	1.08	2.13
WEC12P-16TN-1	3/4	1	.81	1.71	1.05	.81	1.05	1.40	2.74
WEC16P-12TN-1	1	3/4	.63	1.72	1.32	1.03	.75	1.08	2.13
WEC16P-16TN-1	1	1	.88	1.72	1.32	1.03	.75	1.40	2.74

Weld Straight Reducer (Pipe x Pipe)										
PFA Part No.	Pipe Size	Orifice	A	B	C	D1	D2	E	F	G
WSR8P4P	1/2 x 1/4	.35	2.75	.84	.61	1.50	.75	.35	.54	.83
WSR12P4P	3/4 x 1/4	.35	2.75	1.05	.81	1.50	.75	.35	.54	1.11
WSR12P8P	3/4 x 1/2	.61	3.50	1.05	.81	1.50	1.50	.61	.84	1.11
WSR16P4P	1 x 1/4	.35	3.50	1.32	1.03	1.50	.75	.35	.54	1.41
WSR16P8P	1 x 1/2	.61	3.50	1.32	1.03	1.50	1.50	.61	.84	1.41
WSR16P12P	1 x 3/4	.81	3.50	1.32	1.03	1.50	1.50	.81	1.05	1.41

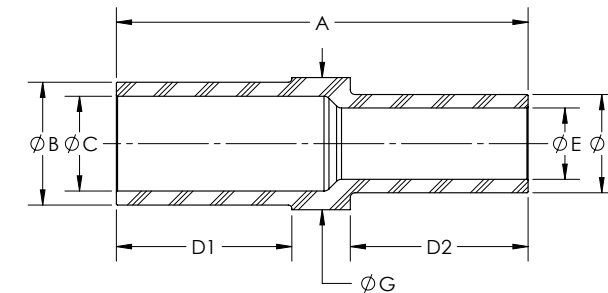

Weld Pipe Cap (Pipe)						
PFA Part No.	Pipe Size	A	B	C	D	E
WCAP4	1/4	.75	.54	.35	.55	.62
WCAP8	1/2	2.00	.84	.61	1.49	.90
WCAP12	3/4	2.01	1.05	.81	1.49	1.11
WCAP16	1	2.01	1.32	1.03	1.49	1.43

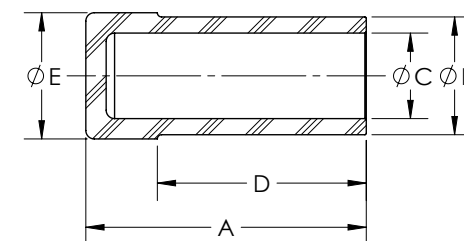



Weld Union Elbow (Pipe x Pipe)					
PFA Part No.	Pipe Size	A	B	C	D
WUE4P	1/4	1.27	.54	.35	.75
WUE8P	1/2	1.47	.84	.61	.75
WUE8PX	1/2	2.22	.84	.61	1.50
WUE12P	3/4	1.55	1.05	.81	.75
WUE12PX	3/4	2.30	1.05	.81	1.50
WUE16P	1	1.50	1.32	1.03	.75
WUE16PX	1	2.18	1.32	1.03	1.48

X = Extended

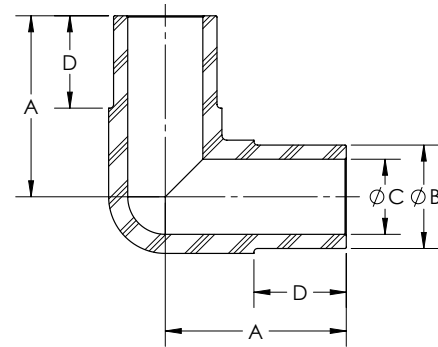

Weld Male Adapter (Pipe x MNPT)								
PFA Part No.	Pipe Size	MNPT Size	Orifice	A	B	C	D	Hex
WMA4P-4	1/4	1/4	.28	1.39	.54	.35	.55	5/8
WMA8P-6	1/2	3/8	.36	2.56	.84	.61	1.49	1
WMA8P-8	1/2	1/2	.51	2.66	.84	.61	1.49	1
WMA12P-8	3/4	1/2	.51	2.66	.84	.61	1.49	1-3/16
WMA12P-12	3/4	3/4	.66	2.68	1.05	.81	1.49	1-3/16
WMA16P-16	1	1	.94	2.85	1.32	1.03	1.49	1-7/16

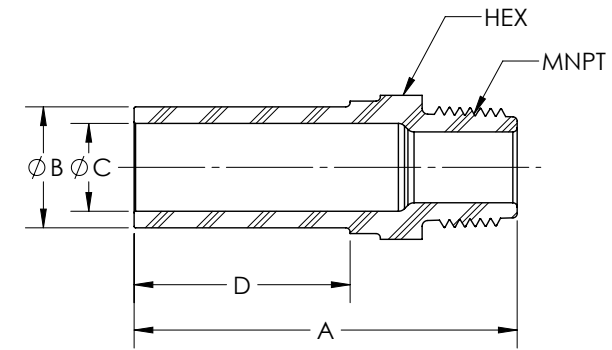

Weld Union Tee (Pipe x Pipe)						
PFA Part No.	Pipe Size	A	B	C	D	E
WUT4P	1/4	2.54	.54	.35	.75	1.27
WUT8P	1/2	2.94	.84	.61	.75	1.47
WUT8PX	1/2	4.44	.84	.61	1.50	2.22
WUT12P	3/4	3.10	1.05	.81	.75	1.55
WUT12PX	3/4	4.60	1.05	.81	1.50	2.30
WUT16P	1	3.00	1.32	1.03	.75	1.50
WUT16PX	1	4.36	1.32	1.03	1.48	2.18

X = Extended

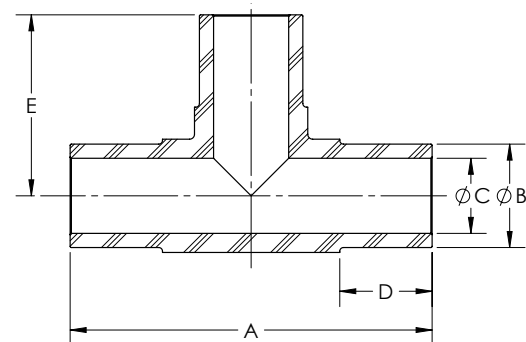

Weld Female Adapter (Pipe x FNPT)								
PFA Part No.	Pipe Size	FNPT Size	Orifice	A	B	C	D	Hex
WFA4P-4	1/4	1/4	.34	1.58	.54	.35	.75	3/4
WFA8P-6	1/2	3/8	.36	2.49	.84	.35	1.49	1
WFA8P-8	1/2	1/2	.51	2.56	.84	.61	1.49	1-3/16
WFA12P-12	3/4	3/4	.79	2.69	1.05	.81	1.49	1-7/16
WFA16P-16	1	1	.99	2.83	1.32	1.03	1.49	1-5/8

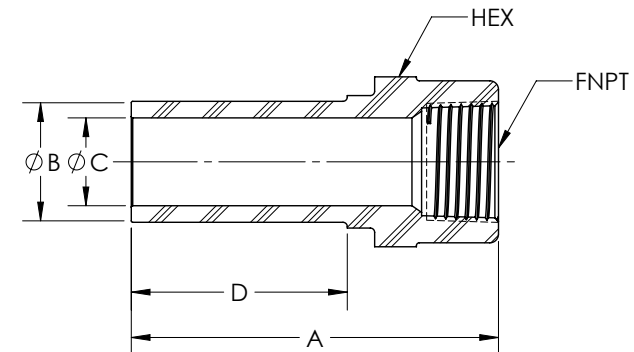



Weld Straight Reducer (Tube x Tube)						
PFA Part No.	Tube OD	A	B	C Orifice	D Orifice	E
WSR6TS4TS	3/8 x 1/4	1.57	.55	.25	.15	.76
WSR8TS4TS	1/2 x 1/4	1.57	.55	.38	.15	.76
WSR8TS6TS	1/2 x 3/8	1.53	.55	.38	.25	.73
WSR12TS4TS	3/4 x 1/4	1.57	.55	.63	.15	.76
WSR12TS6TS	3/4 x 3/8	1.63	.55	.63	.25	.82
WSR12TS8TS	3/4 x 1/2	1.63	.55	.63	.38	.82
WSR16TS4TS	1 x 1/4	1.57	.55	.88	.15	.76
WSR16TS6TS	1 x 3/8	1.63	.55	.88	.25	.82
WSR16TS8TS	1 x 1/2	1.63	.55	.88	.38	.83
WSR16TS12TS	1 x 3/4	1.54	.55	.88	.63	.74
WSR20TS16TS	1-1/4 x 1	1.66	.76	1.10	.88	.65

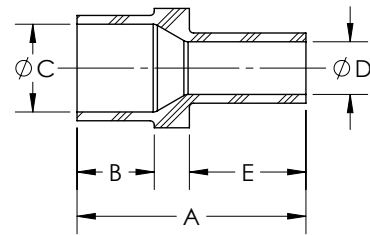

Weld Elbow Reducer (Tube x Tube)							
PFA Part No.	Tube OD	A	B	C Orifice	D Orifice	E	F
WE6TS4TS	3/8 x 1/4	1.42	.90	.25	.15	1.33	.81
WE8TS4TS	1/2 x 1/4	1.68	1.16	.38	.15	1.33	.81
WE8TS6TS	1/2 x 3/8	1.68	1.16	.38	.25	1.42	.90
WE12TS8TS	3/4 x 1/2	1.87	1.18	.63	.38	1.68	1.16
WE16TS8TS	1 x 1/2	2.31	1.36	.88	.38	1.68	1.16
WE16TS12TS	1 x 3/4	2.31	1.36	.88	.63	1.87	1.18

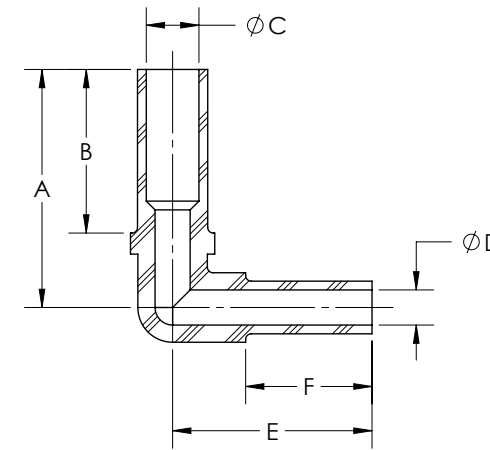

Weld Elbow (Tube x Tube)				
PFA Part No.	Tube OD	A	B	C Orifice
WE4TS	1/4	1.33	.81	.15
WE6TS	3/8	1.42	.90	.25
WE8TS	1/2	1.68	1.16	.38
WE12TS	3/4	1.87	1.18	.63
WE16TS	1	2.31	1.36	.88
WE20TS	1-1/4	2.21	1.26	1.10

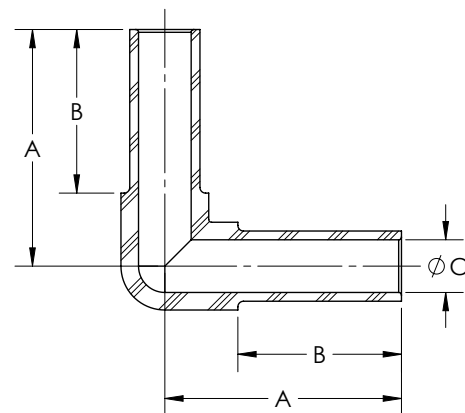

Weld Elbow Sweep (Tube x Tube)				
PFA Part No.	Tube OD	A	B	C Orifice
WES4TS	1/4	1.41	.60	.15
WES6TS	3/8	1.61	.70	.25
WES8TS	1/2	1.79	.80	.38
WES12TS	3/4	2.17	.92	.63
WES16TS	1	2.68	.92	.88

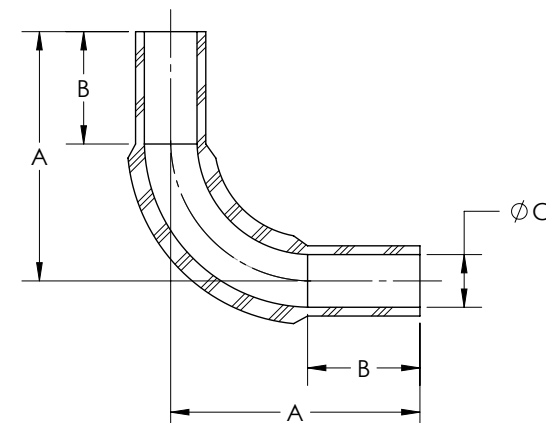

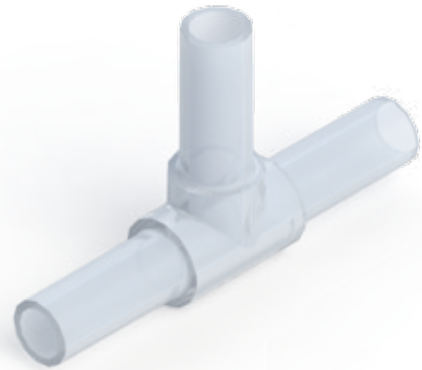

Weld Tee (Tube x Tube x Tube)					
PFA Part No.	Tube OD	A	B	C Orifice	D
WT4TS	1/4	2.66	.81	.15	1.33
WT6TS	3/8	2.82	.90	.25	1.41
WT8TS	1/2	3.37	1.16	.38	1.68
WT12TS	3/4	3.74	1.18	.63	1.87
WT16TS	1	4.62	1.36	.88	2.31
WT20TS	1-1/4	4.42	1.26	1.10	2.21

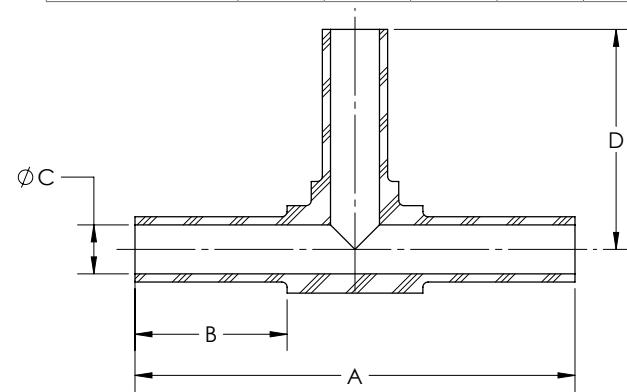

Weld Tee Reducer (Tube x Tube x Tube)								
PFA Part No.	X OD	Y OD	Z OD	A	B	C Orifice	D Orifice	E
WT6TS-4TS-6TS	3/8	1/4	3/8	2.82	.90	.25	.15	1.33
WT8TS-4TS-8TS	1/2	1/4	1/2	3.37	1.16	.38	.15	1.33
WT8TS-6TS-8TS	1/2	3/8	1/2	3.37	1.16	.38	.25	1.41
WT12TS-4TS-12TS	3/4	1/4	3/4	3.74	1.18	.63	.15	1.33
WT12TS-6TS-12TS	3/4	3/8	3/4	3.74	1.18	.63	.25	1.41
WT12TS-8TS-12TS	3/4	1/2	3/4	3.74	1.18	.63	.38	1.68
WT16TS-8TS-16TS	1	1/2	1	4.62	1.36	.88	.38	1.68
WT16TS-12TS-16TS	1	3/4	1	4.62	1.36	.88	.63	1.87
WT20TS-16TS-20TS	1-1/4	1	1-1/4	4.42	1.26	1.10	.88	2.31

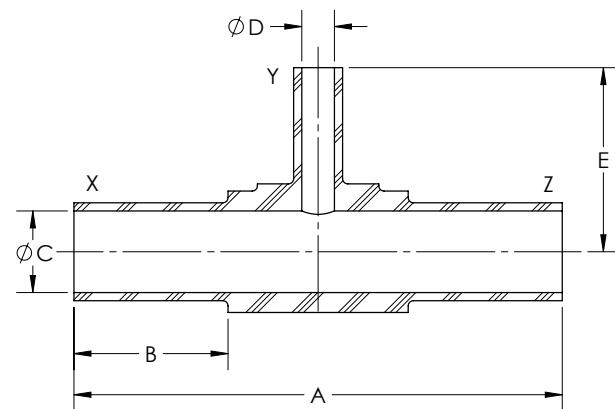

Weld Cross (All Tube)				
PFA Part No.	Tube OD	A	B	C
WX4TS	1/4	1.75	.16	.50
WX6TS	3/8	1.75	.25	.50
WX8TS	1/2	1.75	.38	.50
WX12TS	3/4	2.00	.63	.50
WX16TS	1	2.06	.88	.45
WX20TS	1-1/4	2.64	1.10	.63

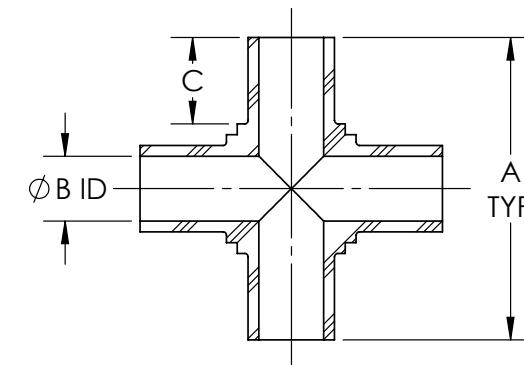

Weld Cross Reducer (All Tube)							
PFA Part No.	Tube OD	A	B	C	D	E	F
WX6TS4TS	3/8 X 1/4	1.75	1.75	.25	.16	.50	.50
WX8TS6TS	1/2 X 3/8	1.75	1.75	.38	.25	.50	.50
WX12TS8TS	3/4 X 1/2	2.00	2.00	.63	.38	.49	.49
WX16TS12TS	1 X 3/4	2.06	2.20	.88	.63	.45	.51

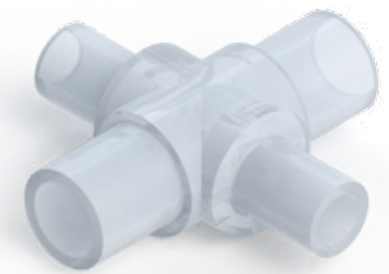
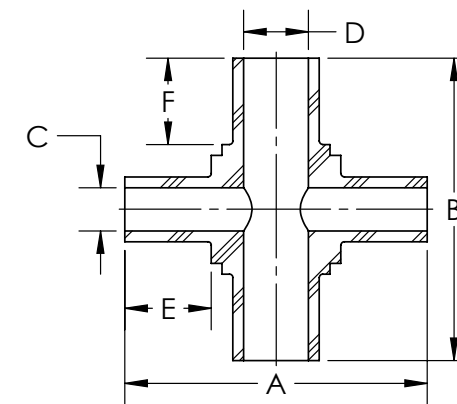

1/4"=6.35mm; 3/8"=9.52mm; 1/2"=12.70mm; 3/4"=19.05mm; 1"=25.40mm and 1-1/4"=31.75mm



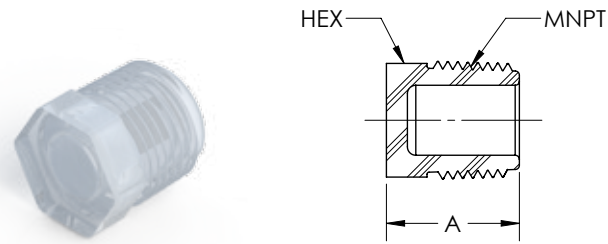

Pipe Plug			
PFA Part No.	MNPT Size	A	Hex
PP2	1/8	.80	1/2
PP4	1/4	.85	5/8
PP6	3/8	.85	11/16
PP8	1/2	.96	13/16
PP12	3/4	.96	1-3/16
PP16	1	1.14	1-7/16

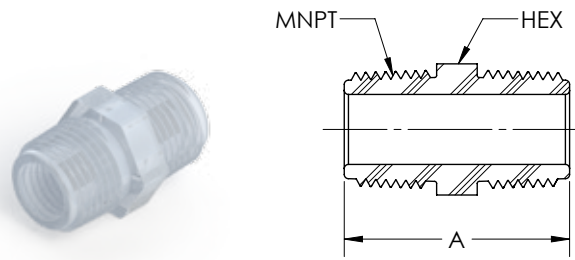

Pipe Nipple			
PFA Part No.	MNPT Size	A	Hex
PN2	1/8	1.31	1/2
PN4	1/4	1.41	5/8
PN6	3/8	1.41	11/16
PN8	1/2	1.61	13/16
PN12	3/4	1.67	1-3/16
PN16	1	2.01	1-7/16

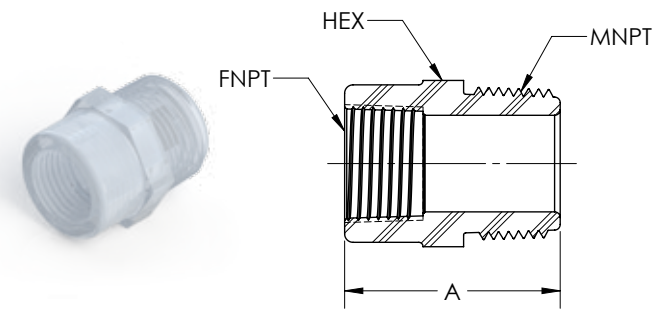

Female Male Connector Reducer				
PFA Part No.	FNPT	MNPT Size	A	Hex
FMCR4-8	1/4	1/2	1.29	13/16
FMCR6-8	3/8	1/2	1.38	15/16
FMCR8-12	1/2	3/4	1.53	1-3/16

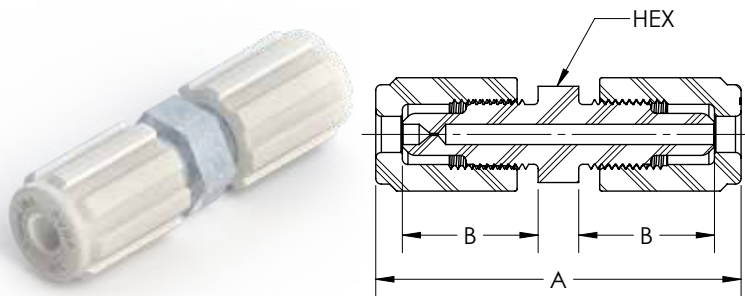

Reduced Orifice Fittings (Straight Union) (Male Flare x Male Flare)					
PFA Part No.	Tube O.D.	Orifice	A	B	Hex
SU44N-1x.030	1/4	.030	2.65	.99	11/16

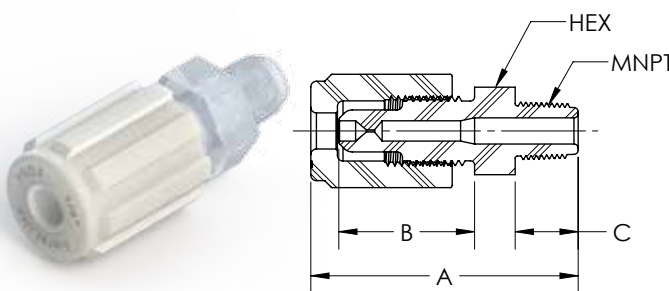

Reduced Orifice Fittings (Male Connector) (Male Flare x MNPT)							
PFA Part No.	Tube O.D.	MNPT Size	Orifice	A	B	C	Hex
MC4-2N-1x.030	1/4	1/8	.030	1.92	.99	.45	5/8
MC4-2N-1x.015	1/4	1/8	.015	1.92	.99	.45	5/8

Male Connector by Sanitary End (Male Flare x Sanitary Size)							
PVDF Part No.	Tube O.D.	Sanitary Size	Orifice	A	B	C	Hex
MC4-MINI	1/4	MINI	.15	2.49	.97	1.12	7/8
MC6-MINI	3/8	MINI	.25	2.58	1.02	1.12	7/8
MC8-MINI	1/2	MINI	.38	2.70	1.15	1.12	7/8
MC8-MAXI	1/2	MAXI	.38	2.83	1.15	1.25	1-3/16
MC12-MINI	3/4	MINI	.56	2.72	1.16	1.12	1-1/8
MC12-MAXI	3/4	MAXI	.63	2.99	1.16	1.25	1-3/16
MC16-MINI	1	MINI	.56	2.92	1.32	1.12	1-7/16
MC16-MAXI	1	MAXI	.86	3.04	1.32	1.25	1-7/16

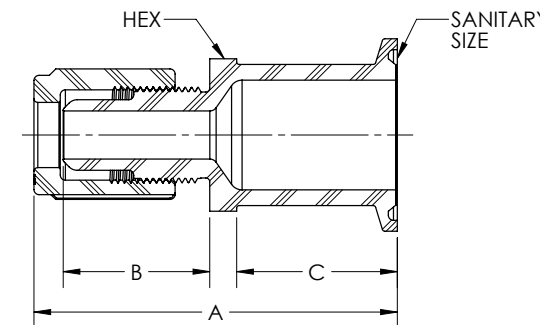

Union Elbow by Sanitary End (Male Flare x Sanitary Size)						
PVDF Part No.	Tube O.D.	Sanitary Size	Orifice	A	B	C
UE12-MINI	3/4	MINI	.56	2.22	1.99	1.63
UE12-MAXI	3/4	MAXI	.63	2.22	1.99	1.95
UE16-MINI	1	MINI	.56	2.71	2.44	1.63
UE16-MAXI	1	MAXI	.86	2.71	2.44	1.95

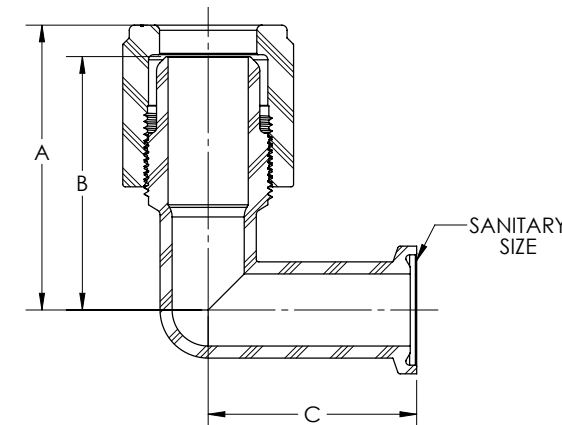

Multi-Flare Panel Mount (Male Flare x Male Flare) Patented									
PVDF Part No.	Tube O.D.	Ports	Orifice	A	B	C	Hex 1	Hex 2	Minimum Panel Hole Diameter
MSUPM4-2	1/4	2	.15	4.13	1.18	1.87	1-3/8	1-1/4	1-1/8
MSUPM4-3	1/4	3	.15	4.13	1.18	1.87	1-3/8	1-1/4	1-1/8
MSUPM4-4	1/4	4	.15	4.13	1.18	1.87	1-1/2	1-3/8	1-1/4
MSUPM4-6	1/4	6	.15	4.13	1.18	1.87	1-3/4	1-5/8	1-1/2

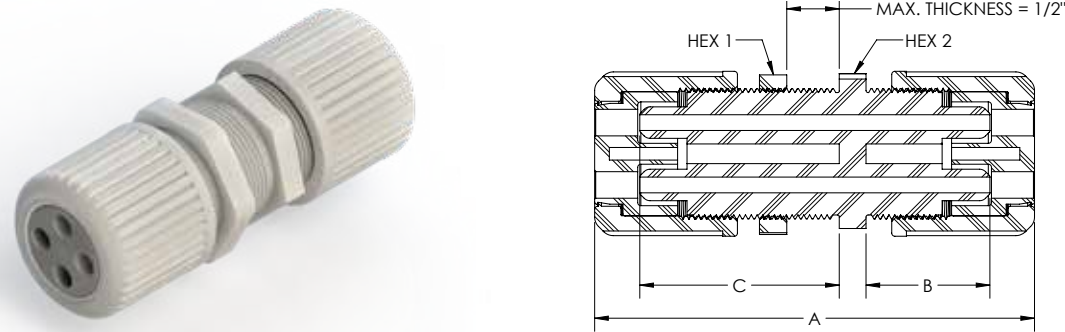

Multi-Flare Male Connector (Male Flare x MNPT) Patented									
PVDF Part No.	Tube O.D.	MNPT Size	Ports	Orifice	A	B	C	Hex	
MMC4-8-2	1/4	1/2	2	.15	2.49	1.18	.66	1-1/4	
MMC4-8-3	1/4	1/2	3	.15	2.49	1.18	.66	1-1/4	
MMC4-12-2	1/4	3/4	2	.15	2.50	1.18	.67	1-1/4	
MMC4-12-3	1/4	3/4	3	.15	2.50	1.18	.67	1-1/4	
MMC4-12-4	1/4	3/4	4	.15	2.50	1.18	.67	1-3/8	
MMC4-16-3	1/4	1	3	.15	2.68	1.18	.85	1-1/4	
MMC4-16-4	1/4	1	4	.15	2.68	1.18	.85	1-3/8	
MMC4-16-6	1/4	1	6	.15	2.68	1.18	.85	1-5/8	



Multi-Flare Transition Fitting (Male Flare x MM Pipe) Patented									
PVDF Part No.	Tube O.D.	Ports	Orifice	A	B	C	D	E	Hex
MTSF4-20MM-2	1/4	2	.15	3.75	1.18	1.50	.64	.79	1-1/4
MTSF4-20MM-3	1/4	3	.15	3.75	1.18	1.50	.64	.79	1-1/4
MTSF4-25MM-2	1/4	2	.15	3.75	1.18	1.50	.82	.98	1-1/4
MTSF4-25MM-3	1/4	3	.15	3.75	1.18	1.50	.82	.98	1-1/4
MTSF4-25MM-4	1/4	4	.15	3.75	1.18	1.50	.82	.98	1-3/8
MTSF4-32MM-3	1/4	3	.15	3.75	1.18	1.50	1.07	1.26	1-1/4
MTSF4-32MM-4	1/4	4	.15	3.75	1.18	1.50	1.07	1.26	1-3/8
MTSF4-32MM-6	1/4	6	.15	3.75	1.18	1.50	1.07	1.26	1-5/8

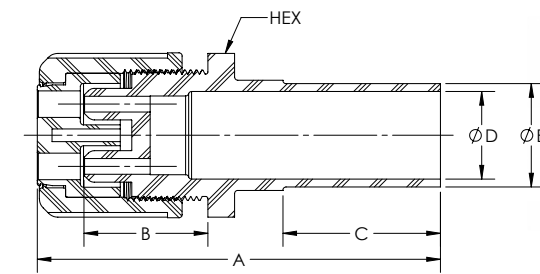

Transition Fitting (Male Flare x MM Pipe)						
PVDF Part No.	Tube O.D.	A	B	C	D	E
TSF4-20MM	1/4	3.30	.79	.64	1.50	3.11
TSF4-25MM	1/4	3.30	.98	.82	1.50	3.11
TSF6-20MM	3/8	3.40	.79	.64	1.50	3.17
TSF6-25MM	3/8	3.40	.98	.82	1.50	3.17
TSF8-20MM	1/2	3.50	.79	.64	1.50	3.28
TSF8-25MM	1/2	3.50	.98	.82	1.50	3.28
TSF8-32MM	1/2	3.50	1.26	1.07	1.50	3.28
TSF8-40MM	1/2	3.50	1.57	1.38	1.50	3.28
TSF12-20MM	3/4	3.64	.79	.64	1.50	3.41
TSF12-25MM	3/4	3.64	.98	.82	1.50	3.41
TSF12-32MM	3/4	3.64	1.26	1.07	1.50	3.41
TSF12-40MM	3/4	3.64	1.57	1.38	1.50	3.41
TSF16-25MM	1	3.80	.98	.82	1.50	3.53
TSF16-32MM	1	3.80	1.26	1.07	1.50	3.53
TSF16-40MM	1	3.80	1.57	1.38	1.50	3.53
TSF16-50MM	1	3.90	1.97	1.73	1.48	3.53
TSF16-63MM	1	3.90	2.48	2.24	1.48	3.53
TSF20-40MM	1-1/4	4.16	1.57	1.38	1.50	3.85
TSF20-50MM	1-1/4	4.16	1.97	1.73	1.48	3.85
TSF20-63MM	1-1/4	4.16	2.48	2.24	1.48	3.85

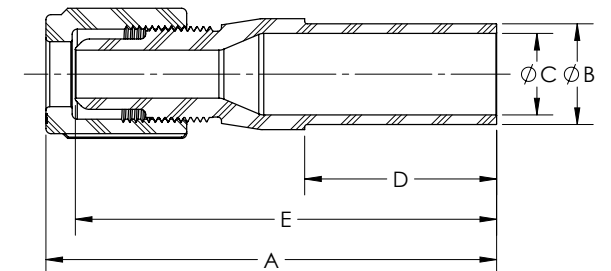

## GrabLOC™ Double Containment Fittings (Non-Terminating)

**PMBP series** panel mount fittings allow the primary and secondary tubes to pass through the fitting body. This allows chemistry to flow back to the supply source if the primary tube leaks.

### Features

- PFA Fitting Body
- PVDF Nut

Part No.	Secondary Containment Tubing	A	B	C	D	Panel Mount Hole	Primary Tubing Sizes
PMBP8GLN-1	1/2	2.79	1.11	.29	.50	1-1/4	1/4
PMBP12GLN-1	3/4	3.01	1.13	.38	.50	1-1/2	1/2, 3/8, 1/4
PMBP16GLN-1	1	3.47	1.27	.38	.50	2	3/4, 1/2, 3/8, 1/4

Tubing not included. Shown for clarity only.

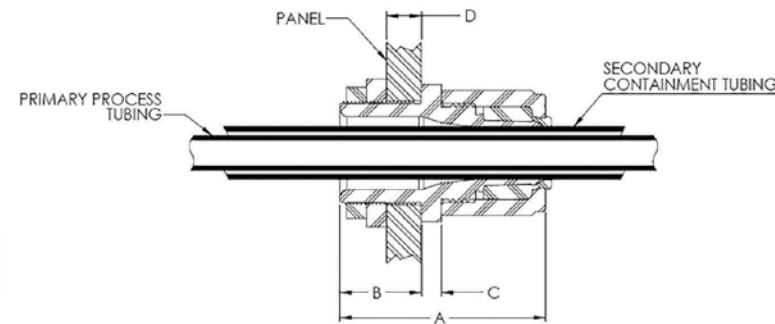

**MCBP series** fittings are used on a box or cabinet that have a female NPT. The primary and secondary tubing pass through the fitting body. This allows chemistry to flow back to the supply source if the primary tube leaks.

### Features

- PFA Fitting Body
- PVDF Nut
- MNPT Connection

Part No.	Secondary Containment Tubing	Male National Pipe Thread (MNPT)	A	B	C	Primary Tubing Sizes
MCBP8GL-12N-1	1/2	3/4	2.35	.67	.29	1/4
MCBP12GL-16N-1	3/4	1	2.73	.85	.38	1/2, 3/8, 1/4
MCBP16GL-20N-1	1	1-1/4	3.07	.86	.38	3/4, 1/2, 3/8, 1/4

Tubing not included. Shown for clarity only.

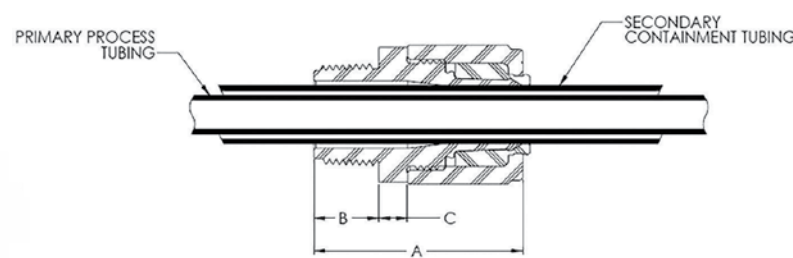

### GrabLOC Wrenches

- Ratcheting action.
- Allows nuts to be rapidly tightened.
- Fits easily in the palm of your hand.



Part No.	Nut Size
DCW8-1	1/2
DCW12-1	3/4
DCW16-1	1
DCW20-1	1-1/4

## GrabLOC™ Double Containment Fittings (Terminating)

**PMDC series** fittings are a conventional panel mount connection. The primary tubing passes through the fitting body with a simple push-on secondary tube terminating the tube connection. There is no flaring required of the secondary tube.

Part No.	Primary Process Tubing	Secondary Containment Tubing	A	B	C	D	Panel Mount Hole
PMDC48GLN-1	1/4	1/2	2.62	1.10	.29	.50	1
PMDC612GLN-1	3/8	3/4	2.79	1.11	.29	.50	1-1/4
PMDC812GLN-1	1/2	3/4	2.79	1.11	.29	.50	1-1/4
PMDC816GLN-1	1/2	1	3.36	1.57	.29	.50	1-1/2
PMDC1216GLN-1	3/4	1	3.01	1.13	.38	.50	1-1/2
PMDC1620GLN-1	1	1-1/4	3.47	1.27	.38	.50	2

Tubing not included. Shown for clarity only.

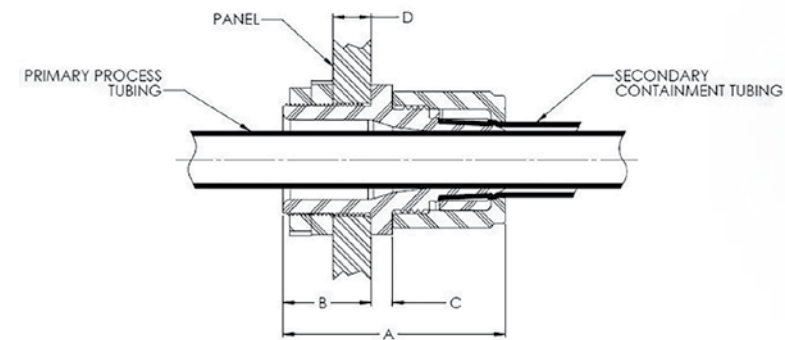

**MCDC series** fittings are used on a box or cabinet that have a female NPT. The primary tubing passes through the fitting body with a simple push-on secondary tubing terminating the tube connection. There is no flaring required of the secondary tube.

Part No.	Primary Process Tubing	Secondary Containment Tubing	Male National Pipe Thread (MNPT)	A	B	C
MCDC48GL-8N-1	1/4	1/2	1/2	2.17	.66	.29
MCDC612GL-12N-1	3/8	3/4	3/4	2.35	.67	.29
MCDC812GL-12N-1	1/2	3/4	3/4	2.35	.67	.29
MCDC816GL-16N-1	1/2	1	1	2.73	.85	.38
MCDC1216GL-16N-1	3/4	1	1	2.73	.85	.38
MCDC1620GL-20N-1	1	1-1/4	1-1/4	3.07	.86	.38

Tubing not included. Shown for clarity only.

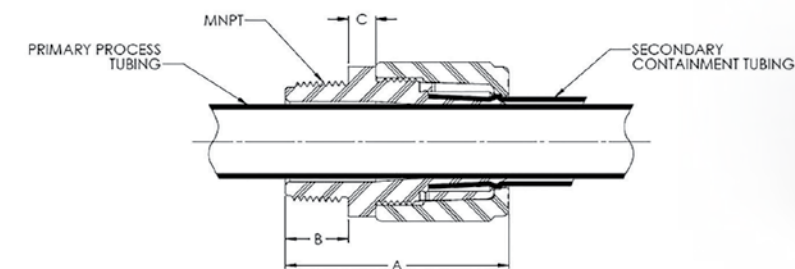

### Features

- PFA Fitting Body
- PVDF Nut

### Features

- PFA Fitting Body
- PVDF Nut
- MNPT Connection

# GrabLOC™ Double Containment Tee

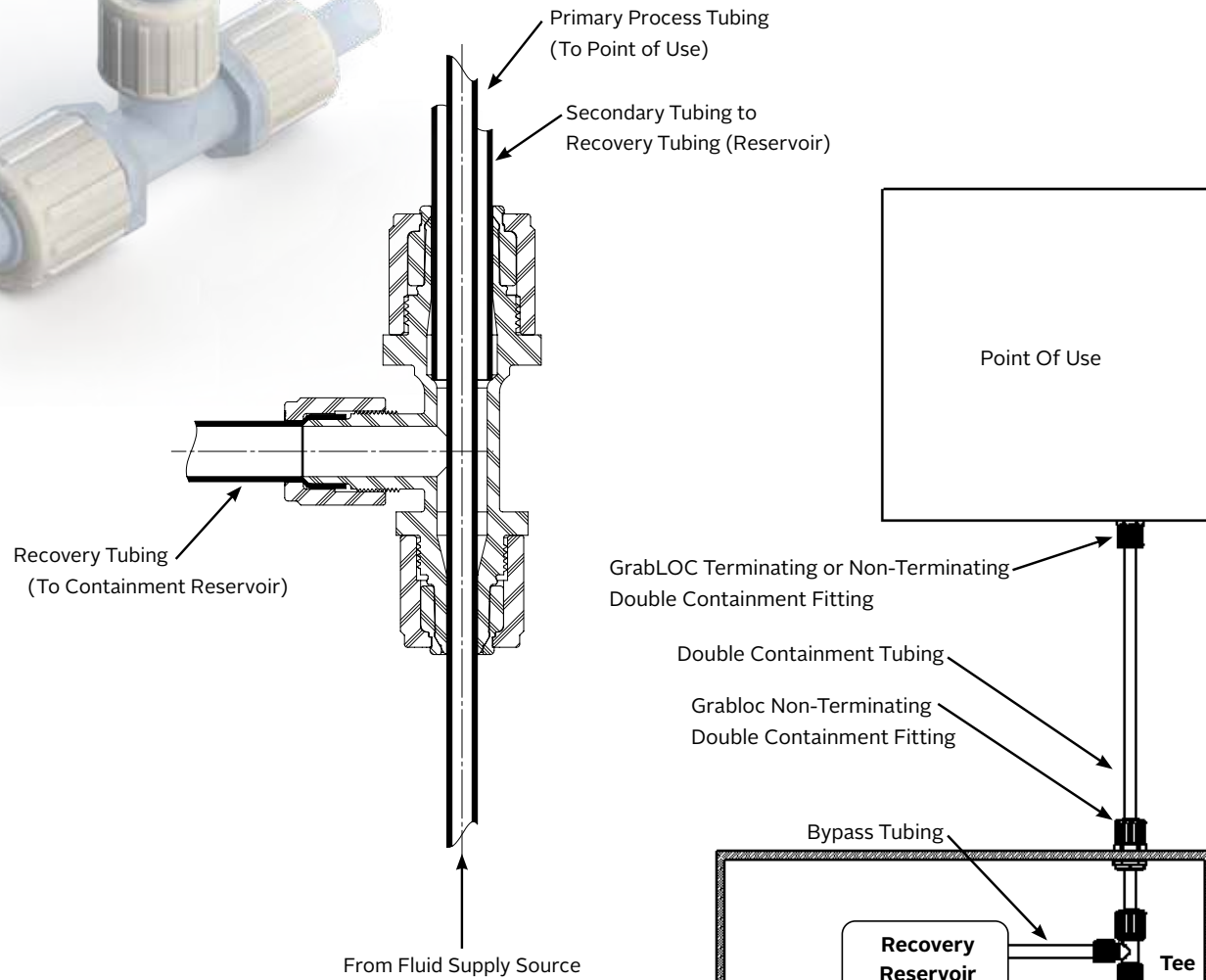

Part No.	Secondary Containment Tubing	Recovery Tubing	Primary Process Tubing
GLT8BP-8-4BPN-1	1/2	1/2	1/4
GLT12BP-8-6BPN-1	3/4	1/2	3/8
GLT12BP-12-8BPN-1	3/4	3/4	1/2
GLT16BP-12-8BPN-1	1	3/4	1/2
GLT16BP-16-12BPN-1	1	1	3/4
GLT20BP-16-16BPN-1	1-1/4	1	1

Patent Pending Tubing not included. Shown for clarity only.

# WELDED SYSTEMS Fabricated Manifolds

You can go from your sketch, to a CAD model, to a finished, welded manifold in a matter of days.

From concept to CAD model, fabrication and delivery, Fit-LINE provides a turn-key solution for fast turnaround of customer-specified manifolds. With over 30 years of fluoropolymer and injection molding expertise, Fit-LINE's proprietary, patented methods reduce the time needed to create custom manifolds in a matter of days, not weeks.

Manufactured from high purity virgin PFA and PVDF resins in dedicated molds and process equipment, Fit-LINE's custom manifolds are designed to maximize throughput of aggressive chemistry and ultra-pure water applications, they are available from 1/4 inch to 1-1/2 inch in diameter.

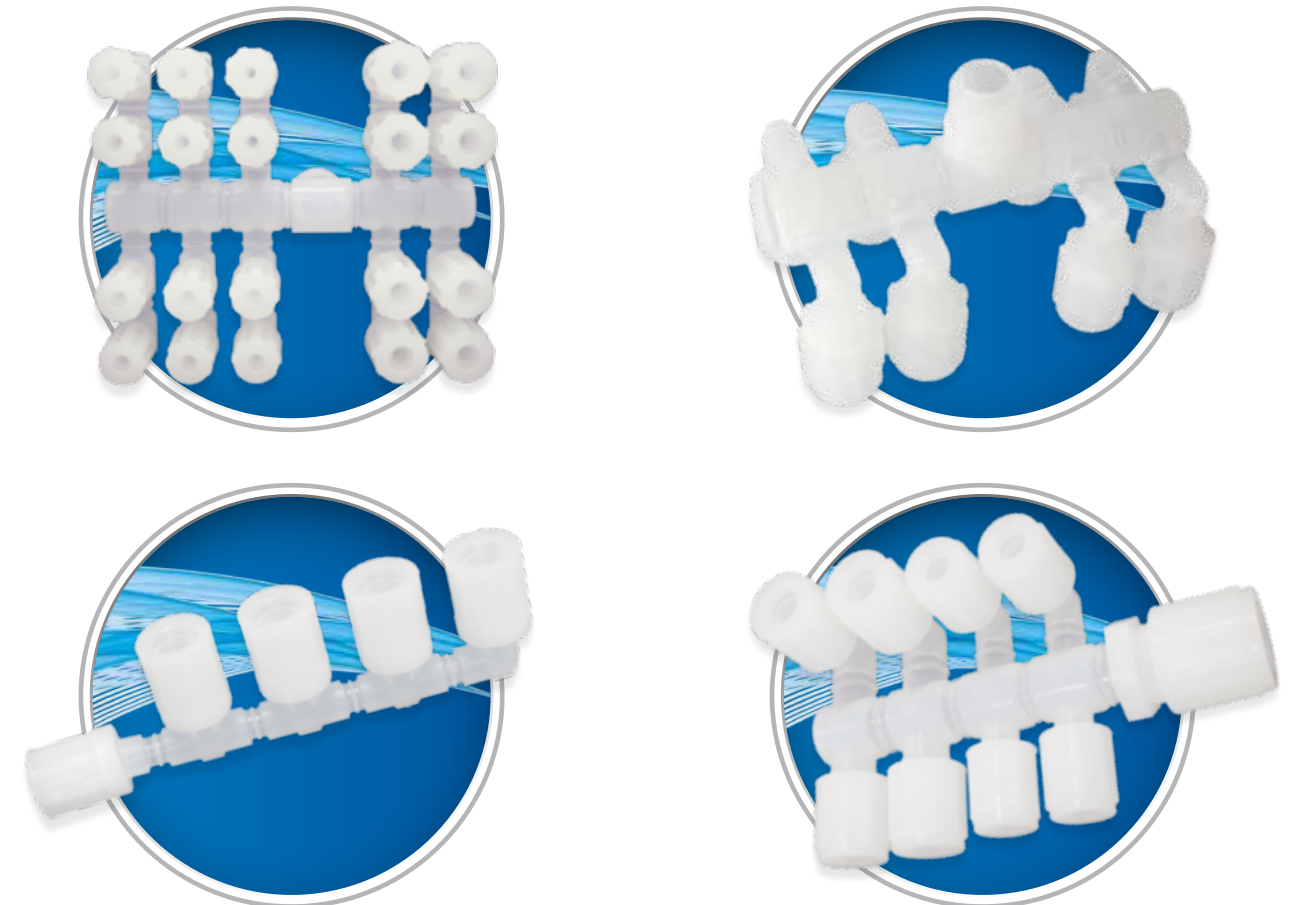

# Products & Services Available Worldwide



Visit us at [FitLineInc.com](http://FitLineInc.com) to find a distributor nearest you.

## WARRANTY

Fit-LINE warrants to the BUYER that any product sold will be free from defects in material or workmanship for a period of twelve (12) months from the date of shipment. If during the warranty period, the BUYER notifies Fit-LINE of a defect, Fit-LINE shall, at its option, repair or replace the defective material or workmanship. OTHER THAN AS EXPRESSLY STATED HEREIN, FIT-LINE MAKES NO OTHER WARRANTIES, EXPRESS OR IMPLIED, REGARDING THE PRODUCTS AND/OR SERVICES PROVIDED HEREUNDER, AND EXPRESSLY DISCLAIMS THE IMPLIED WARRANTIES OF NON-INFRINGEMENT, MERCHANTABILITY AND FITNESS FOR A PARTICULAR PURPOSE. The BUYER shall bear the cost of freight to and from Fit-LINE'S plant. BUYER agrees to accept the limits of liability as expressed in this statement to the exclusion of any and all provisions regarding statements of liability on the BUYER's own invoices, purchase orders and/or other documents.

## GOODS

All descriptions and illustrations contained in Fit-LINE'S catalog, brochures, price lists, website, advertisements and all specifications, drawings and any other documents contained therein submitted with any QUOTATION to BUYER or otherwise communicated to BUYER are intended merely to present a general idea of GOODS and SERVICES (GOODS) described therein and nothing contained in any of them shall form any part of the contract.



2901 Tech Center Drive, Santa Ana, CA 92705  
Phone: (714) 549-9091 Email: [info@FitLineInc.com](mailto:info@FitLineInc.com)