

TOM JOINT FITTING

AUTOMATIC TUBE WELD GLANDS



SANKO KOGYO CO., LTD.

<http://www.jsk-sanko.co.jp>

AUTOMATIC TUBE WELD GLANDS

components are ordered by product code as listed in this catalogue

DESIGNATIONS PART NUMBER SYSTEM						
M	E	4	S		EP	WELD FITTING
T	LG	8	S	19	BA	TOM JOINT
① Series	② Product	③ Size	④ Material	⑤ Gland Length (Gland Only)	⑥ Finishing	
① Series	③ Size	④ Material	⑤ Gland Length	⑥ Finishing		
M: Micro Fitting L=6.35 m/m	2 : 1/8" OD	S=Single Melting	6 : 6.35mm	BA		
S: Short Fitting L= 10m/m	4 : 1/4" OD	V=Double Melting	10 : 10mm	EP		
L: Forged Fitting L=19.05m/m	6 : 3/8" OD		12 : 19.05mm			
T: Tom Joint (Metal Seal)	8 : 1/2" OD					
	12 : 3/4" OD					
	16 : 1" OD					
Product						
E	Elbow		LG	Male Gland		
T	Tee		BU	Bulkhead Union		
CT	Cross		UC	Union Cross		
TB	Tribow		MC	Male Connector		
R	Reducer		ME	Male Elbow		
FN	Female Nut		UT	Union Tee		
MN	Male Nut		MU	Double Male Union		
CP	Cap		UE	Union Elbow		
PG	Plug		HLG	H-VCR Male Gland		
GT	Gasket		HFN	H-VCR Female Nut		
GR	Gasket w/Retainer		HMN	H-VCR Male Nut		
SG	Female Gland					



JSK

TOM JOINT FITTINGS

AUTOMATIC TUBE WELD FITTINGS



WELD FITTINGS

- Micro Weld Fittings
- Forged Weld Fittings

Features

- 316L VIM/VAR Material
- Permanently Heat code marked; traceable to original mill certificate of test.
- Electropolished components permanently marked with designator on cube (P or PX)
- Critical surfaces are 100% visually inspected using magnification and lighting.

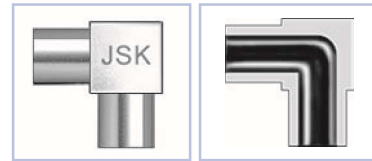

Materials

316L VIM/VAR Material complies with ASTM A276 and ASME SA479. Recommended tubing specifications include ASME SA213, ASTM A213, ASTM A249, ASTM A269, MIL T8504, MIL T8506 and JIS G4303.

Specifications

- **Pressure Ratings** will be governed by the tubing selected for a particular application. Working Pressures are calculated below for tubing using maximum allowable stress levels in accordance with ASME/ANSI B31.3, at ambient temperature.

Tube O.D.	Pressure Rating		Normal Wall Thickness mm
	psig	kgf/cm ²	
1/4"OD	5100	358	1.0 (0.89)
3/8"OD	3300	232	1.0 (0.89)
1/2"OD	3500	246	1.24mm
3/4"OD	2400	160	1.24mm

Optional: 1/4"OD Wall Thickness 0.89mm

- **Dimensions** are for reference only and are subject to change.
- **Internal Surface Finishes:** Standard finish Micro Fittings have an internal Surface Roughness of 3.0 $\mu\text{m Ry}$. Electropolished Micro Fittings have an internal Surface Roughness of 0.7 $\mu\text{m Ry}$.

Designator	Surface Finish(Ry)
	Maximum
EP	0.7 μm
BA	3.0 μm



Micro Weld Fittings

□: BA or EP

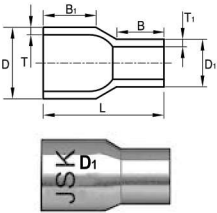

Micro Reducer (MR)

Size (OD)	Size (OD ₁)	Ordering Number	D	D ₁	T	T ₁	B	B ₁	L
3/8"	1/4"	MR64S□	9.53	6.35	1.00	1.00	6.35	10.4	19.1
1/2"	1/4"	MR84S□	12.70	6.35	1.24	1.00	6.35	10.4	19.1
1/2"	3/8"	MR86S□	12.70	9.53	1.24	1.00	6.35	10.4	19.1
3/4"	1/4"	MR124S□	19.05	6.35	1.24	1.00	6.35	10.4	19.1
3/4"	3/8"	MR126S□	19.05	9.53	1.24	1.00	6.35	10.4	19.1
3/4"	1/2"	MR128S□	19.05	12.70	1.24	1.24	6.35	10.4	19.1

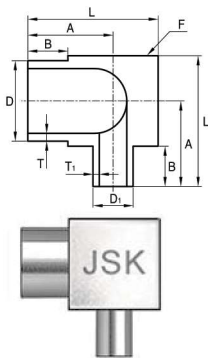

Micro Reducing 90° Elbow (ME)

Size (OD)	Size (OD ₁)	Ordering Number	D	D ₁	T	T ₁	A	B	F Body Cube	L
3/8"	1/4"	ME64S□	9.53	6.35	1.00	1.00	11.91	6.35	11.11	17.46
1/2"	1/4"	ME84S□	12.70	6.35	1.24	1.00	13.50	6.35	14.29	20.64
1/2"	3/8"	ME86S□	12.70	9.53	1.24	1.00	13.50	6.35	14.29	20.64
3/4"	1/4"	ME124S□	19.05	6.35	1.24	1.00	16.68	6.35	20.65	27.00
3/4"	3/8"	ME126S□	19.05	9.53	1.24	1.00	16.68	6.35	20.65	27.00
3/4"	1/2"	ME128S□	19.05	12.70	1.24	1.24	16.68	6.35	20.65	27.00

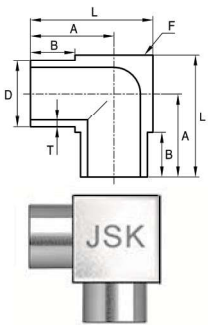

Micro 90° Elbow (ME)

Size (OD)	Ordering Number	D	T	A	B	F Body Cube	L
1/4"	ME4S□	6.35	1.00	10.32	6.35	7.94	14.29
3/8"	ME6S□	9.53	1.00	11.91	6.35	11.11	17.46
1/2"	ME8S□	12.70	1.24	13.50	6.35	14.29	20.64
3/4"	ME12S□	19.05	1.24	16.68	6.35	20.65	27.00

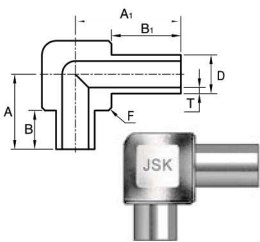

Micro Extended Leg 90° Elbow (MEL)

Size (OD)	Ordering Number	D	T	A	A ₁	B	B ₁	F Body Cube
1/4"	MEL4S□	6.35	1.00	12.30	17.38	6.35	11.43	11.11

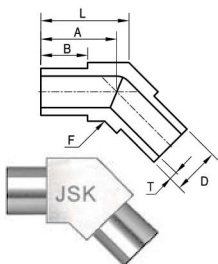

Micro 45° Elbow (MEF)

Size (OD)	Ordering Number	D	T	A	B	F Body Cube	L
1/4"	MEF4S□	6.35	1.00	10.32	6.35	7.94	11.96
3/8"	MEF6S□	9.53	1.00	11.91	6.35	11.11	14.21
1/2"	MEF8S□	12.70	1.24	13.50	6.35	14.29	16.46
3/4"	MEF12S□	19.05	1.24	16.68	6.35	20.65	20.95

• Dimensions are for reference only and are subject to change.



Micro Weld Fittings

□: BA or EP

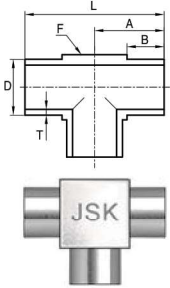

Micro Tee (MT)							
Size (OD)	Ordering Number	D	T	A	B	F Body Cube	L
1/4"	MT4S□	6.35	1.00	10.32	6.35	7.94	20.64
3/8"	MT6S□	9.53	1.00	11.91	6.35	11.11	23.81
1/2"	MT8S□	12.70	1.24	13.50	6.35	14.29	26.99
3/4"	MT12S□	19.05	1.24	16.68	6.35	20.65	33.35

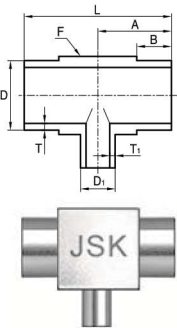

Micro Reducing Tee (MT)										
Size (OD)	Size (OD ₁)	Ordering Number	D	D ₁	T	T ₁	A	B	F Body Cube	L
3/8"	1/4"	MT64S□	9.53	6.35	1.00	1.00	11.91	6.35	11.11	23.81
1/2"	1/4"	MT84S□	12.70	6.35	1.24	1.00	13.50	6.35	14.29	26.99
1/2"	3/8"	MT86S□	12.70	9.53	1.24	1.00	13.50	6.35	14.29	26.99
3/4"	1/4"	MT124S□	19.05	6.35	1.24	1.00	16.68	6.35	20.65	27.00
3/4"	3/8"	MT126S□	19.05	9.53	1.24	1.00	16.68	6.35	20.65	27.00
3/4"	1/2"	MT128S□	19.05	12.70	1.24	1.24	16.68	6.35	20.65	27.00

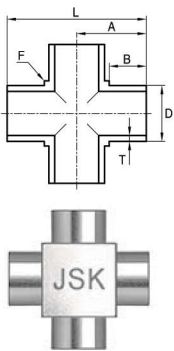

Micro Cross (MCT)								
Size (OD)	Ordering Number	D	T	A	B	F Body Cube	L	
1/4"	MCT4S□	6.35	1.00	10.32	6.35	7.94	20.64	
3/8"	MCT6S□	9.53	1.00	11.91	6.35	11.11	23.81	
1/2"	MCT8S□	12.70	1.24	13.50	6.35	14.29	26.99	
3/4"	MCT12S□	19.05	1.24	16.68	6.35	20.65	33.35	

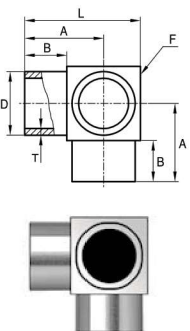

Micro Tribow (MTB)							
Size (OD)	Ordering Number	D	T	A	B	F Body Cube	L
1/4"	MTB4S□	6.35	1.00	10.32	6.35	7.94	14.29
3/8"	MTB6S□	9.53	1.00	11.91	6.35	11.11	17.46
1/2"	MTB8S□	12.70	1.24	13.50	6.35	14.29	20.64
3/4"	MTB12S□	19.05	1.24	16.68	6.35	20.65	27.00

●Dimensions are for reference only and are subject to change.



Forged Weld Fittings

□: BA or EP

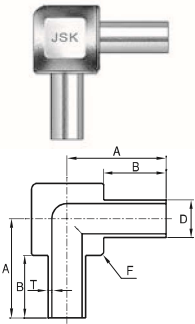

90° Elbow (LE,SE)

Size (OD)	Ordering Number	D	T	A	B	F Body Cube
1/4"	LE4S□	6.35	1.00	25.0	19.05	11.2
3/8"	LE6S□	9.53	1.00	25.0	19.05	11.2
1/2"	LE8S□	12.70	1.24	29.0	19.05	17.5
3/4"	LE12S□	19.05	1.24	31.5	19.05	25.0
1/4"	SE4S□	6.35	1.00	15.9	10.00	11.2
3/8"	SE6S□	9.53	1.00	15.9	10.00	11.2
1/2"	SE8S□	12.70	1.24	19.9	10.00	17.5
3/4"	SE12S□	19.05	1.24	22.4	10.00	25.0

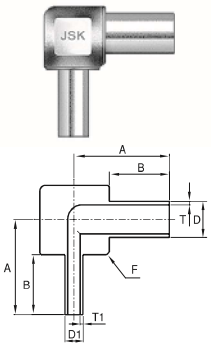

Reducing 90° Elbow (LE)

Size (OD)	Size (OD ₁)	Ordering Number	D	D ₁	T	T ₁	B	A	F Body Cube
3/8"	1/4"	LE64S□	9.53	6.35	1.00	1.00	19.05	25	11.2
1/2"	1/4"	LE84S□	12.70	6.35	1.24	1.00	19.05	29	17.5
1/2"	3/8"	LE86S□	12.70	9.53	1.24	1.00	19.05	29	17.5

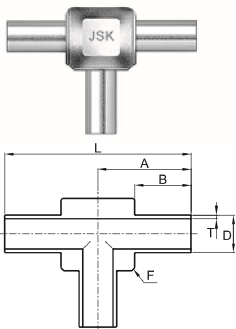

Tee (LT,ST)

Size (OD)	Ordering Number	D	T	A	B	F Body Cube	L
1/4"	LT4S□	6.35	1.00	25.0	19.05	11.2	50.0
3/8"	LT6S□	9.53	1.00	25.0	19.05	11.2	50.0
1/2"	LT8S□	12.70	1.24	29.0	19.05	17.5	58.0
3/4"	LT12S□	19.05	1.24	31.5	19.05	25.0	63.0
1/4"	ST4S□	6.35	1.00	15.9	10.00	11.2	31.8
3/8"	ST6S□	9.53	1.00	15.9	10.00	11.2	31.8
1/2"	ST8S□	12.70	1.24	19.9	10.00	17.5	39.8
3/4"	ST12S□	19.05	1.24	22.4	10.00	25.0	44.8

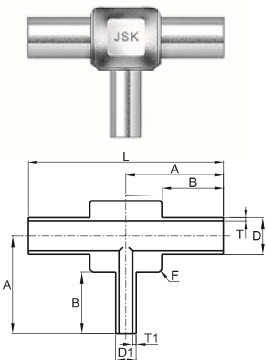

Reducing Tee (LT,ST)

Size (OD)	Size (OD ₁)	Ordering Number	D	D ₁	T	T ₁	A	B	F Body Cube	L
3/8"	1/4"	LT64S□	9.53	6.35	1.00	1.00	25.0	19.05	11.2	50.0
1/2"	1/4"	LT84S□	12.70	6.35	1.24	1.00	29.0	19.05	17.5	58.0
1/2"	3/8"	LT86S□	12.70	9.53	1.24	1.00	29.0	19.05	17.5	58.0
3/4"	1/4"	LT124S□	19.05	6.35	1.24	1.00	31.5	19.05	25.0	63.0
3/4"	3/8"	LT126S□	19.05	9.53	1.24	1.00	31.5	19.05	25.0	63.0
3/4"	1/2"	LT128S□	19.05	12.70	1.24	1.24	31.5	19.05	25.0	63.0
3/8"	1/4"	ST64S□	9.53	6.35	1.00	1.00	15.9	10.00	11.2	31.8
1/2"	1/4"	ST84S□	12.70	6.35	1.24	1.00	19.9	10.00	17.5	39.8
1/2"	3/8"	ST86S□	12.70	9.53	1.24	1.00	19.9	10.00	17.5	39.8
3/4"	1/4"	ST124S□	19.05	6.35	1.24	1.00	22.4	10.00	25.0	44.8
3/4"	3/8"	ST126S□	19.05	9.53	1.24	1.00	22.4	10.00	25.0	44.8

•Dimensions are for reference only and are subject to change.



Forged Weld Fittings

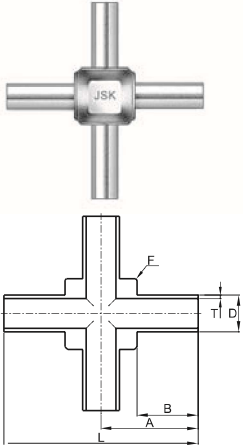

□: BA or EP

Cross (LCT,SCT)

Size (OD)	Ordering Number	D	T	A	B	F Body Cube	L
1/4"	LCT4S□	6.35	1.00	25.0	19.05	11.2	50.0
3/8"	LCT6S□	9.53	1.00	25.0	19.05	11.2	50.0
1/2"	LCT8S□	12.70	1.24	29.0	19.05	17.5	58.0
3/4"	LCT12S□	19.05	1.24	31.5	19.05	25.0	63.0
1/4"	SCT4S□	6.35	1.00	15.9	10.00	11.2	31.8
3/8"	SCT6S□	9.53	1.00	15.9	10.00	11.2	31.8
1/2"	SCT8S□	12.70	1.24	19.9	10.00	17.5	39.8
3/4"	SCT12S□	19.05	1.24	22.4	10.00	25.0	44.8

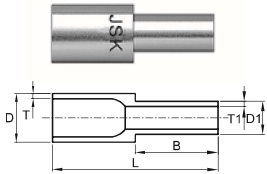

Reducer (LR,SR)

Size (OD)	Size (OD ₁)	Ordering Number	D	D ₁	T	T ₁	B	L
3/8"	1/4"	LR64S□	9.53	6.35	1.00	1.00	19.05	38.1
1/2"	1/4"	LR84S□	12.70	6.35	1.24	1.00	19.05	38.1
1/2"	3/8"	LR86S□	12.70	9.53	1.24	1.00	19.05	38.1
3/4"	1/4"	LR124S□	19.05	6.35	1.24	1.00	19.05	42.9
3/4"	3/8"	LR126S□	19.05	9.53	1.24	1.00	19.05	42.9
3/4"	1/2"	LR128S□	19.05	12.70	1.24	1.24	19.05	42.9
3/8"	1/4"	SR64S□	9.53	6.35	1.00	1.00	10.00	20.0
1/2"	1/4"	SR84S□	12.70	6.35	1.24	1.00	10.00	20.0
1/2"	3/8"	SR86S□	12.70	9.53	1.24	1.00	10.00	20.0
3/4"	1/4"	SR124S□	19.05	6.35	1.24	1.00	10.00	20.0
3/4"	3/8"	SR126S□	19.05	9.53	1.24	1.00	10.00	20.0
3/4"	1/2"	SR128S□	19.05	12.70	1.24	1.24	10.00	20.0

●Dimensions are for reference only and are subject to change.



JSK



TOM JOINT FITTING

- Glands
- Welded Assemblies
- Gaskets
- Nuts, Caps and Plugs
- High-Flow Connections - "H" Type

- **High-Purity Nickel and Hastelloy C-22** glands for extremely corrosive applications.
- **Non-Rotational Female Nut** to prevent transmission of torque during make-up and therefore minimize twist of component which causes stress concentration.

Materials

Glands, Bodies and Nuts

Material	Ordering Number Designator	Applicable Specification
316L stainless steel Single Melt	S	bar stock : ASME SA479, ASTM A276 forgings : ASTM A182
316L VAR(Vacuum Arc Remelt) stainless steel Double Melt	V	bar stock : ASME SA479, ASTM A276 forgings : ASTM A182

Some Configuration

Gaskets

Material	Ordering Number Designator	Applicable Specification
Nickel	NI	ASTM B162
316L stainless steel	US	ASTM A167
Silver plated 316L stainless steel	SS	ASTM A167

Specifications

- **Pressure Ratings** are based upon tests conducted using VCR assemblies. All ratings comply with calculations per ANSI Code for Pressure Piping B31.3.
- **Working Pressures** are rated at ambient temperature and are based on a 4 to 1 design factor. To determine pressure ratings in accordance with ANSI B31.1 multiply **Working Pressures** by 0.94.
- **Temperature Ratings**
 Fittings: Stainless Steel 316, 316L 1000°F (537°C)
 Gaskets: High-Purity Nickel 600°F (315°C)
 Stainless Steel 1000°F (537°C)
- **Dimensions** are for reference only and are subject to change
- **Plating** Female nuts are silver plated. Avoid chemical processes used for cleaning, electropolishing, and passivation that will remove plating. If the plating is damage or removed, thread galling may occur, damaging fitting components and preventing a proper seal.

- **Testing** products are rated to a Helium leak rate of 1×10^{-9} atm cc/sec.
- **Internal Surface Finishes:** components are available with controlled surface finishes and electropolished internal surfaces.
- **Cleaning and Packaging:** Ultra-High Purity cleaning and packaging in a Class 100 Clean Room environment validated per Federal Standard 209E, is standard for all electropolished components.

Designator	Surface Finish(Ry)
	Maximum
EP	0.7 um
BA	3.0 um

Typical Face Seal Fittings

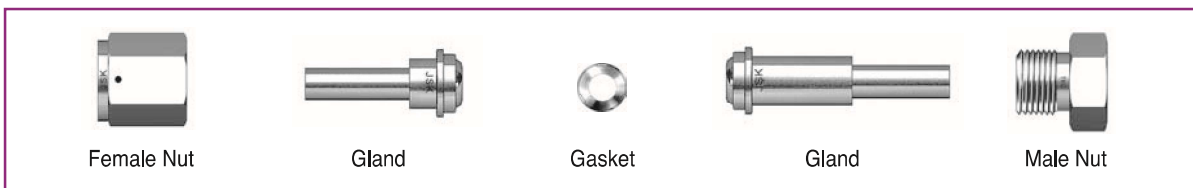

Female Nut

Gland

Gasket

Gland

Male Nut



□: BA or EP

Glands

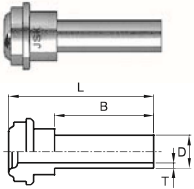

Female Gland (TSG)							
Head Size	Tube Size(OD)	Ordering Number	D	T	B	L	ANS (Inch)
1/8"	1/8"	TSG2S19□	3.18	0.70	19.05	27.40	1/8
1/4"	1/4"	TSG4S6□	6.35	1.00	6.35	15.24	1/4
1/4"	1/4"	TSG4S10□	6.35	1.00	10.00	18.89	1/4
1/4"	1/4"	TSG4S19□	6.35	1.00	19.05	27.94	1/4
1/2"	3/8"	TSG6S6□	9.53	1.00	6.35	15.75	1/2
1/2"	3/8"	TSG6S10□	9.53	1.00	10.00	19.40	1/2
1/2"	3/8"	TSG6S19□	9.53	1.00	19.05	28.45	1/2
1/2"	1/2"	TSG8S6□	12.70	1.24	6.35	15.75	1/2
1/2"	1/2"	TSG8S10□	12.70	1.24	10.00	19.40	1/2
1/2"	1/2"	TSG8S19□	12.70	1.24	19.05	28.45	1/2
3/4"	3/4"	TSG12S19□	19.05	1.24	19.05	34.50	3/4
1"	1"	TSG16S19□	25.40	1.65	19.05	38.60	1
1/2"	1/4"	TSG84S6□	6.35	1.00	6.35	15.75	1/2
1/2"	1/4"	TSG84S10□	6.35	1.00	10.00	19.40	1/2
1/2"	1/4"	TSG84S19□	6.35	1.00	19.05	28.45	1/2

ANS : AVAILABLE NUT SIZE

Male Gland (TLG)							
Head Size	Tube Size(OD)	Ordering Number	D	T	B	L	ANS (Inch)
1/8"	1/8"	TLG2S19□	3.18	0.70	19.05	36.00	1/8
1/4"	1/4"	TLG4S6□	6.35	1.00	6.35	30.48	1/4
1/4"	1/4"	TLG4S10□	6.35	1.00	10.00	34.13	1/4
1/4"	1/4"	TLG4S19□	6.35	1.00	19.05	43.18	1/4
1/2"	3/8"	TLG6S6□	9.53	1.00	6.35	32.77	1/2
1/2"	3/8"	TLG6S10□	9.53	1.00	10.00	36.42	1/2
1/2"	3/8"	TLG6S19□	9.53	1.00	19.05	45.47	1/2
1/2"	1/2"	TLG8S6□	12.70	1.24	6.35	32.77	1/2
1/2"	1/2"	TLG8S10□	12.70	1.24	10.00	36.42	1/2
1/2"	1/2"	TLG8S19□	12.70	1.24	19.05	45.47	1/2
3/4"	3/4"	TLG12S19□	19.05	1.24	19.05	51.56	3/4
1"	1"	TLG16S19□	25.40	1.65	19.05	58.93	1
1/2"	1/4"	TLG84S6□	6.35	1.00	6.35	32.77	1/2
1/2"	1/4"	TLG84S10□	6.35	1.00	10.00	36.42	1/2
1/2"	1/4"	TLG84S19□	6.35	1.00	19.05	45.47	1/2

ANS : AVAILABLE NUT SIZE

Male Weld Gland (TMG)							
Head Size	Tube Size(OD)	Ordering Number	D	E	B	L	ANS (Inch)
1/8"	1/8"	TMG2S□	3.18	1.5	7.1	17.8	1/8
1/4"	1/4"	TMG4S□	6.35	3.0	10.5	33.5	1/4
1/2"	3/8"	TMG6S□	9.53	7.1	10.5	38.0	1/2
1/2"	1/2"	TMG8S□	12.70	10.2	12.7	38.0	1/2

ANS : AVAILABLE NUT SIZE

Tube Adapter (TTA)							
Head Size	Tube Size(OD)	Ordering Number	D	E	B	L	ANS (Inch)
1/4"	1/4"	TMA4S□	6.35	4.3	16	41	1/4
1/2"	3/8"	TMA6S□	9.53	6.8	18	46	1/2
1/2"	1/2"	TMA8S□	12.70	9.4	24	49	1/2

ANS : AVAILABLE NUT SIZE

●Dimensions are for reference only and are subject to change.

□: BA or EP

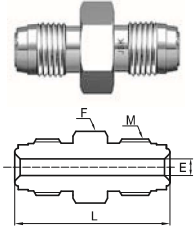

Double Male Union (TMU)

Head Size	Ordering Number	E	L	F Body Cube	M
1/8"	TMU2S□	2.30	28.70	9.52	5/16-24 UNF
1/4"	TMU4S□	4.35	39.37	15.88	9/16-18 UNF
1/2"	TMU8S□	10.22	46.74	23.81	7/8-14 UNF
3/4"	TMU12S□	15.75	61.98	33.34	1 1/4 -18UNEF
1"	TMU16S□	22.10	65.79	41.28	1 1/2-2OUN

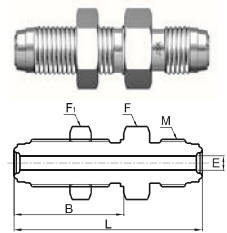

Bulkhead Union (TBU)

Head Size	Ordering Number	E	B	L	F Body Cube	F1 Body Cube	M
1/4"	TBU4S□	4.35	33.00	56.60	19.05	15.88	9/16-18 UNF
1/2"	TBU8S□	10.22	37.60	65.25	26.90	23.81	7/8-14 UNF
3/4"	TBU12S□	15.75	43.40	79.00	38.10	33.34	1 1/4-18 UNEF
1"	TBU16S□	22.10	47.10	86.00	44.40	41.28	1 1/2-2OUN

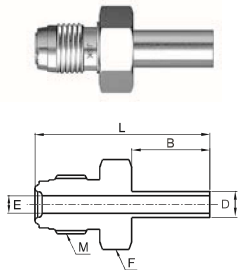

TBW Body (TTB)

Head Size	Tube Size(OD)	Ordering Number	D	B	E	L	F Body Cube	M
1/4"	1/4"	TTB44S□	6.35	19.05	4.35	42.65	15.88	9/16-18 UNF
1/2"	3/8"	TTB86S□	9.53	19.05	10.22	46.70	23.81	7/8-14 UNF
1/2"	1/2"	TTB88S□	12.70	19.05	10.22	46.70	23.81	7/8-14 UNF
3/4"	3/4"	TTB1212S□	19.05	19.05	15.75	55.55	33.34	1 1/4-18 UNEF

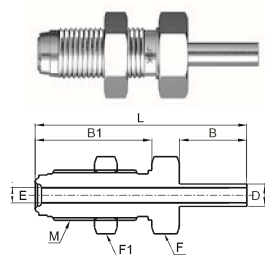

TBW Bulkhead Connector (TTBC)

Head Size	Tube Size(OD)	Ordering Number	D	E	B	B1	L	F Body Cube	F1 Body Cube	M
1/4"	1/4"	TTBC44S□	6.35	4.35	19.05	33.00	59.85	19.05	15.88	9/16-18 UNF
1/2"	1/2"	TTBC88S□	12.70	10.22	19.05	37.60	65.25	26.90	23.81	7/8-14 UNF
3/4"	3/4"	TTBC1212S□	19.05	15.75	19.05	43.25	71.30	38.10	33.34	1 1/4-18 UNEF

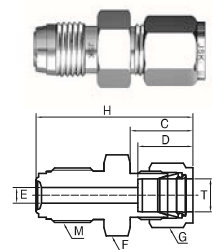

Tube Fitting Connector (TTFC)

Head Size	Tube Size(OD)	Ordering Number	C	D	E	F Body Cube	G	H	T	M
1/4"	1/4"	TTFC44S□	17.80	15.20	4.35	15.90	14.29	41.1	1/4"	9/16-18 UNF
1/2"	3/8"	TTFC86S□	19.30	16.80	10.22	23.81	17.46	46.7	3/8"	7/8-14 UNF
1/2"	1/2"	TTFC88S□	21.80	22.90	10.22	23.81	22.23	49.5	1/2"	7/8-14 UNF

●Dimensions are for reference only and are subject to change.

□: BA or EP

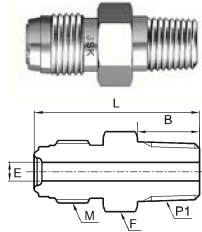

Male Connector(PT) (TMCR)							
Head Size	M-PT P1	Ordering Number	E	B	L	F Body Cube	M
1/8"	1/8"	TMCR22S□	2.30	9.60	27.20	11.11	5/16-24 UNF
1/4"	1/4"	TMCR44S□	4.35	14.22	37.84	15.90	9/16-18 UNF
1/2"	3/8"	TMCR86S□	7.44	14.22	41.87	23.80	7/8-14 UNF
1/2"	1/2"	TMCR88S□	10.22	19.05	46.74	23.80	7/8-14 UNF
3/4"	3/4"	TMCR1212S□	15.75	19.05	55.63	33.30	1 1/4-18 UNEF
1"	1"	TMCR1616S□	22.10	23.88	62.74	42.20	1 1/2-20UN

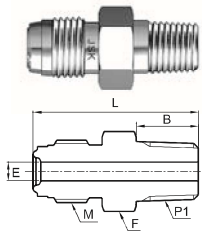

Male Connector(NPT) (TMCN)							
Head Size	M-NPT P1	Ordering Number	E	B	L	F Body Cube	M
1/8"	1/8"	TMCN22S□	2.30	9.60	27.20	11.11	5/16-24 UNF-2A
1/4"	1/4"	TMCN44S□	4.35	14.22	37.84	15.90	9/16-18 UNF
1/2"	3/8"	TMCN86S□	7.44	14.22	41.87	23.80	7/8-14 UNF
1/2"	1/2"	TMCN88S□	10.22	19.05	46.74	23.80	7/8-14 UNF
3/4"	3/4"	TMCN1212S□	15.75	19.05	55.63	33.30	1 1/4-18 UNEF
1"	1"	TMCN1616S□	22.10	23.88	62.74	42.20	1 1/2-20UN

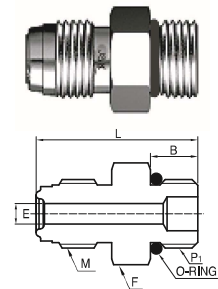

Male Connector(ST) (TMCS)								
Head Size	ST P1	Ordering Number	E	B	L	F Body Cube	M	UNIFORM O-Ring Size
1/4"	9/16-18 UNF	TMCS44S□	4.35	9.9	33.8	19.05	9/16-18 UNF	F-904
1/2"	7/8-14 UNF	TMCS88S□	10.22	12.7	42.2	25.40	7/8-14 UNF	F-908
3/4"	1 3/16-12 UNF	TMCS1212S□	15.75	15.0	51.5	34.90	1 1/4-18 UNEF	F-912

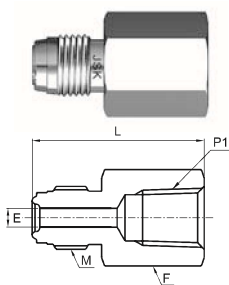

Female Connector(PT) (TFCR)						
Head Size	F-PT P1	Ordering Number	E	F	L	M
1/8"	1/8"	TFCR22S□	2.30	14.28	30.2	5/16-24 UNF
1/4"	1/4"	TFCR44S□	4.35	19.05	39.1	9/16-18 UNF
1/2"	3/8"	TFCR86S□	7.44	23.81	44.7	7/8-14 UNF
1/2"	1/2"	TFCR88S□	10.22	26.98	50.5	7/8-14 UNF
3/4"	3/4"	TFCR1212S□	15.75	33.33	59.9	1 1/4-18 UNEF
1"	1"	TFCR1616S□	22.10	41.27	63.8	1 1/2-20UN

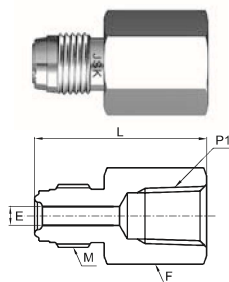

Female Connector(NPT) (TFCN)						
Head Size	F-NPT P1	Ordering Number	E	F	L	M
1/8"	1/8"	TFCN22S□	2.30	14.28	30.2	5/16-24 UNF
1/4"	1/4"	TFCN44S□	4.35	19.05	39.1	9/16-18 UNF
1/2"	3/8"	TFCN86S□	7.44	23.81	44.7	7/8-14 UNF
1/2"	1/2"	TFCN88S□	10.22	26.98	50.5	7/8-14 UNF
3/4"	3/4"	TFCN1212S□	15.75	33.33	59.9	1 1/4-18 UNEF
1"	1"	TFCN1616S□	22.10	41.27	63.8	1 1/2-20UN

•Dimensions are for reference only and are subject to change.

☐: BA or EP

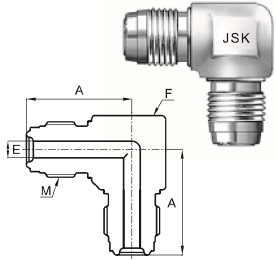

Union Elbow (TUE)					
Head Size	Ordering Number	E	A	F Body Cube	M
1/4"	TUE4S☐	4.35	27.18	15.9	9/16-18 UNF
1/2"	TUE8S☐	10.22	36.83	23.8	7/8-14 UNF
3/4"	TUE12S☐	15.75	48.77	33.3	1 1/4-18 UNEF
1"	TUE16S☐	22.10	50.80	42.2	1 1/2-20UN

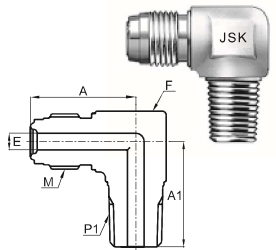

Male Elbow (PT) (TMER)							
Head Size	M-PT P1	Ordering Number	E	A	A1	F Body Cube	M
1/4"	1/4"	TMER44S☐	4.35	27.18	27.18	15.9	9/16-18 UNF
1/2"	3/8"	TMER86S☐	10.22	36.83	32.00	23.8	7/8-14 UNF
1/2"	1/2"	TMER88S☐	10.22	36.83	36.83	23.8	7/8-14 UNF
3/4"	3/4"	TMER1212S☐	15.75	48.80	43.50	33.3	1 1/4-18UNEF

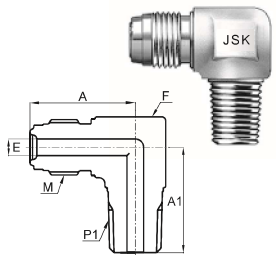

Male Elbow (NPT) (TMEN)							
Head Size	M-NPT P1	Ordering Number	E	A	A1	F Body Cube	M
1/4"	1/4"	TMEN44S☐	4.35	27.18	27.18	15.9	9/16-18 UNF
1/2"	3/8"	TMEN86S☐	10.22	36.83	32.00	23.8	7/8-14 UNF
1/2"	1/2"	TMEN88S☐	10.22	36.83	36.83	23.8	7/8-14 UNF
3/4"	3/4"	TMEN1212S☐	15.75	48.80	43.50	33.3	1 1/4-18UNEF

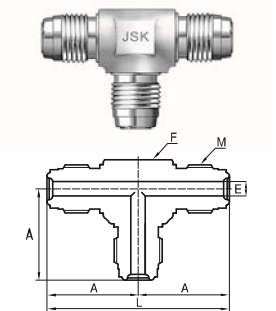

Union Tee (TUT)						
Head Size	Ordering Number	E	A	L	F Body Cube	M
1/4"	TUT4S☐	4.35	27.18	54.36	15.9	9/16-18 UNF
1/2"	TUT8S☐	10.22	36.83	73.66	23.8	7/8-14 UNF
3/4"	TUT12S☐	15.75	48.77	97.54	33.3	1 1/4-18 UNEF
1"	TUT16S☐	22.10	50.80	101.60	42.2	1 1/2-20UN

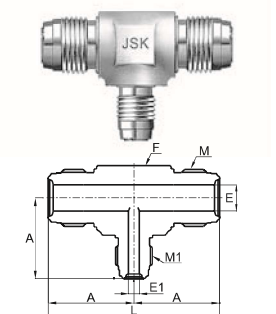

Reducing Union Tee (TUT)								
Head Size	Ordering Number	E	E ₁	A	L	F Body Cube	M	M ₁
1/2" X 1/4"	TUT84S☐	10.22	4.35	36.83	73.66	23.8	7/8-14 UNF	9/16-18 UNF
3/4" X 1/4"	TUT124S☐	15.75	4.35	48.77	97.54	33.8	1 1/4-18 UNEF	9/16-18 UNF
3/4" X 1/2"	TUT128S☐	15.75	10.22	48.77	97.54	33.8	1 1/4-18 UNEF	7/8-14 UNF

● Dimensions are for reference only and are subject to change.



JSK

TOM JOINT FITTINGS

AUTOMATIC TUBE WELD GLANDS

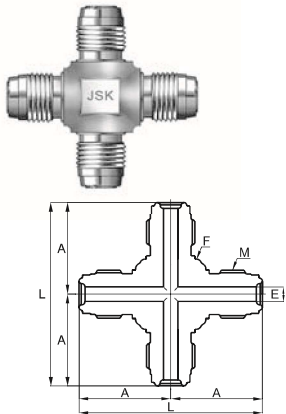

☐: BA or EP

Union Cross (TUC)

Head Size	Ordering Number	E	A	L	F Body Cube	M
1/4"	TUC4S☐	4.35	27.18	54.36	15.9	9/16-18 UNF
1/2"	TUC8S☐	10.22	36.83	73.66	23.8	7/8-14 UNF
3/4"	TUC12S☐	15.75	48.77	97.54	33.3	1 1/4-18 UNEF
1"	TUC16S☐	22.10	50.80	101.60	42.2	1 1/2-20UN

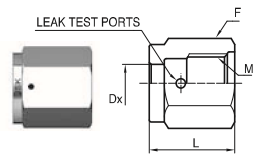

Female Nut (TFN)

Head Size	Ordering Number	L	F Hex Flat	DX	M
1/8"	TFN2S	13.5	11.11	5.30	5/16-24UNF
1/4"	TFN4S	20.5	19.05	9.10	9/16-18 UNF
1/2"	TFN8S	22.3	26.99	15.50	7/8-14 UNF
3/4"	TFN12S	28.4	38.10	22.60	1 1/4-18 UNEF
1"	TFN16S	34.0	44.45	30.50	1 1/2-20UN

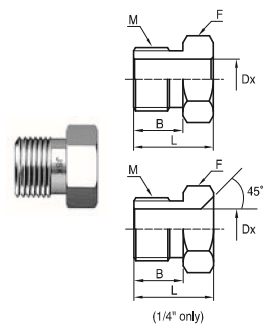

Male Nut (TMN)

Head Size	Ordering Number	L	B	F Hex Flat	DX	M
1/8"	TMN2S	12.7	8.2	9.52	5.30	5/16-24 UNF
1/4"	TMN4S	18.0	11.0	15.88	9.10	9/16-18 UNF
*1/4"	TMN4S.54	13.7	11.0	15.88	9.10	9/16-18 UNF
1/2"	TMN8S	20.5	12.7	23.81	15.50	7/8-14 UNF
3/4"	TMN12S	25.4	16.0	33.34	22.60	1 1/4-18 UNEF
1"	TMN16S	30.2	20.0	41.28	30.50	1 1/2-20UN

TMNS : Short Male Nut 1/4" Only

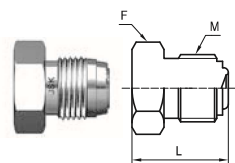

Plug (TPG)

Head Size	Ordering Number	L	F Hex Flat	M
1/8"	TPG2S☐	17.30	9.52	5/16-24 UNF
1/4"	TPG4S☐	23.37	15.88	9/16-18 UNF
1/2"	TPG8S☐	27.43	23.81	7/8-14 UNF
3/4"	TPG12S☐	36.32	33.34	1 1/4-18 UNEF
1"	TPG16S☐	38.61	41.28	1 1/2-20UN

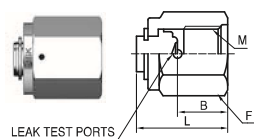

Cap (TCP)

Head Size	Ordering Number	L	B	F Hex Flat	M
1/8"	TCP2S☐	16.00	7.60	11.11	5/16-24 UNF
1/4"	TCP4S☐	23.88	11.18	19.05	9/16-18 UNF
1/2"	TCP8S☐	25.65	11.43	26.99	7/8-14 UNF
3/4"	TCP12S☐	32.77	13.72	38.10	1 1/4-18 UNEF
1"	TCP16S☐	39.12	16.00	44.45	1 1/2-20UN

☐: BA or EP

Dimensions are for reference only and are subject to change.

□=NI, US, SS
 NI : Nickel EP
 US : Original 316L EP
 SS : Silver plated 316L EP

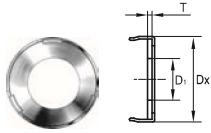

Gasket w/Retainer (TGR)				
Head Size	Ordering Number	T	D1	DX
1/4"	TGR4□	0.8	5.6	11.85
1/2"	TGR8□	0.8	11.2	19.27
3/4"	TGR12□	0.8	16.7	27.90
1"	TGR16□	0.8	22.6	34.20

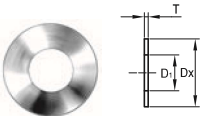

Gasket (TGT)				
Head Size	Ordering Number	T	D1	Dx
1/8"	TGT2□	0.8	2.3	6.6
1/4"	TGT4□	0.8	5.6	12.7
1/2"	TGT8□	0.8	11.2	19.8
3/4"	TGT12□	0.8	16.7	29.0
1"	TGT16□	0.8	22.6	35.8

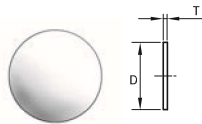

Blind Gasket (TBG)				
Head Size	Ordering Number	D	T	
1/4"	TBG4□	11.9	0.8	
1/2"	TBG8□	19.8	0.8	
3/4"	TBG12□	28.9	0.8	
1"	TBG16□	35.5	0.8	

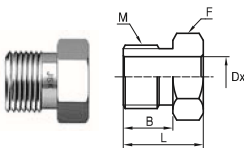

Hi-Flow

HVCR Male Nut (THMN)						
Head Size	Ordering Number	B	L	F Hex Flat	DX	M
1/4"	THMN4S	11.0	18.03	15.88	9.9	9/16-18 UNF

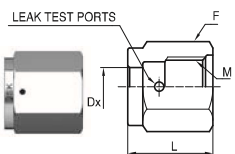

Hi-Flow

HVCR Female Nut (THFN)					
Head Size	Ordering Number	L	F Hex Flat	Dx	M
1/4"	THFN4S	20.57	19.05	9.90	9/16-18 UNF

•Dimensions are for reference only and are subject to change.

Hi-Flow

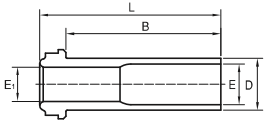

HVCR Long Gland (THLG)							
Head Size	Tube Size(OD)	Ordering Number	D	B	L	E	E1
1/4"	3/8"	THLG46S□	9.35	28.4	33.2	7.5	6.28

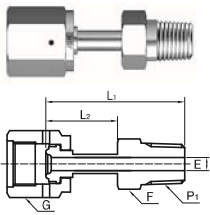

Welded Male Connector(PT) (TWMCR)							
Head Size	M-PT P1	Ordering Number	E	F Hex Flat	G Hex Flat	L1	L2
1/4"	1/4"	TWMCR44S□	4.35	14.29	19.05	45.5	23.4
1/2"	3/8"	TWMCR86S□	7.44	17.46	26.99	48.0	25.4
1/2"	1/2"	TWMCR88S□	10.22	22.23	26.99	53.1	25.6

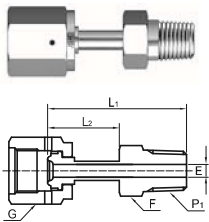

Welded Male Connector(NPT) (TWMCN)							
Head Size	M-NPT P1	Ordering Number	E	F Hex Flat	G Hex Flat	L1	L2
1/4"	1/4"	TWMCN44S□	4.35	14.29	19.05	45.5	23.4
1/2"	3/8"	TWMCN86S□	7.44	17.46	26.99	48.0	25.4
1/2"	1/2"	TWMCN88S□	10.22	22.23	26.99	53.1	25.6

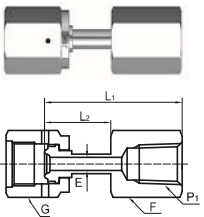

Welded Female Connector(PT) (TWFCR)							
Head Size	F-PT P1	Ordering Number	E	F Hex Flat	G Hex Flat	L1	L2
1/4"	1/4"	TWFCR44S□	4.35	19.05	19.05	45.0	23.4
1/2"	3/8"	TWFCR86S□	7.44	22.23	26.99	49.5	26.9
1/2"	1/2"	TWFCR88S□	10.22	26.99	26.99	55.4	26.4

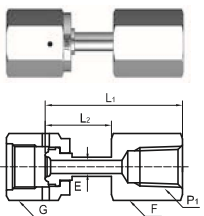

Welded Female Connector(NPT) (TWFCN)							
Head Size	F-NPT P1	Ordering Number	E	F Hex Flat	G Hex Flat	L1	L2
1/4"	1/4"	TWFCN44S□	4.35	19.05	19.05	45.0	23.4
1/2"	3/8"	TWFCN86S□	7.44	22.23	26.99	49.5	26.9
1/2"	1/2"	TWFCN88S□	10.22	26.99	26.99	55.4	26.4

□: BA or EP

●Dimensions are for reference only and are subject to change.



JSK

TOM JOINT FITTINGS

AUTOMATIC TUBE WELD GLANDS

□: BA or EP

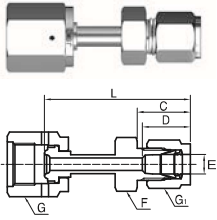

Welded Lok Connector (TWLC)

Head Size	Tube Size(OD)	Ordering Number	C	D	E	F Hex Flat	G Hex Flat	G1 Hex Flat	H
1/4"	1/4"	TWLC44S□	17.78	15.24	4.35	12.70	19	17	49.28
1/2"	3/8"	TWLC86S□	19.30	16.76	7.44	15.88	19	19	50.04
1/2"	1/2"	TWLC88S□	21.84	22.86	10.22	20.64	26	19	56.64

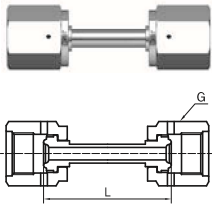

Welded Female Union (TWFU)

Head Size	Ordering Number	L	G
1/4"	TWFU4S□	43.4	19.05
1/2"	TWFU8S□	46.7	26.99

Female Elbow Union Welded Assembly

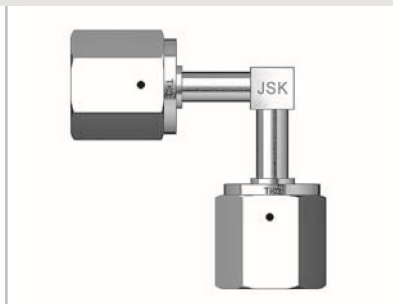

Ordering Number / TFEU4S□

Female Tee Union Welded Assembly

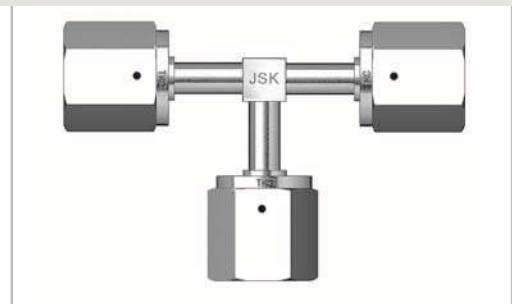

Ordering Number / TFFTU4S□

•Dimensions are for reference only and are subject to change.



SANKO KOGYO CO., LTD.

Head Office

2-22-13, Yaguchi, Ohta-ku, Tokyo, JAPAN

TEL. 81-3-3750-1253

FAX. 81-3-3750-1229

E-mail : sales@jsk-sanko.co.jp

http://www.jsk-sanko.co.jp



Assembly:

Step 1:

Place the gasket into the female nut, and make sure the gasket is settled in proper position.

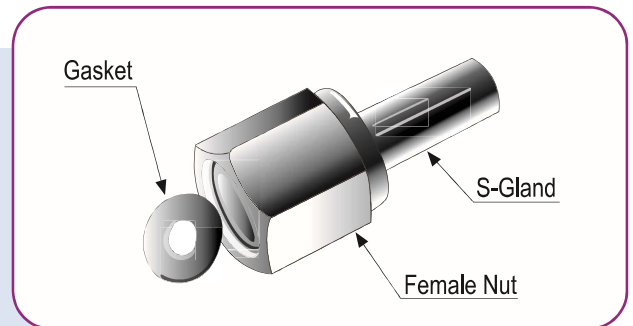

Step 2:

Assemble the components as shown in the picture. Screw tight the components as shown in the picture.

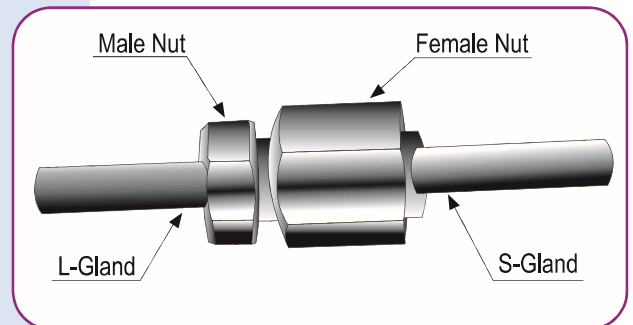

Step 3:

Make sure male nut and female nut are tightened, and scribe an aligned line of the hex face of male nut and female nut.

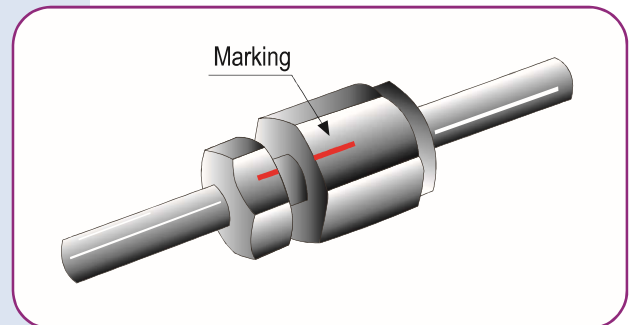

Step 4:

Final tightening requires assembly tools such as wrenches or spanners. Hold the male nut with the tool and screw the female nut 1/8 turn.

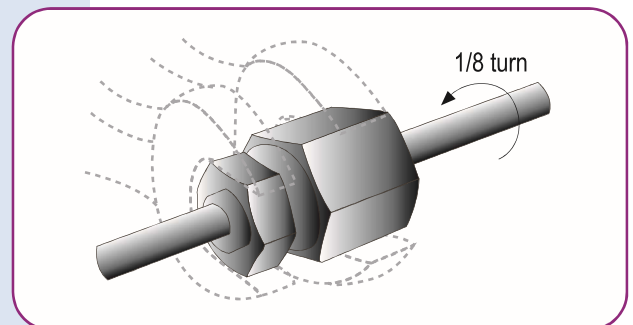

Caution:

over tightening the components will damage the triode surface and cause potential leakage.

Protective Cap:

Removing VCR components in an assembled unit needs minimal clearance. Loosen the female nut by holding the male nut or body hex with a backup wrench in order to remove a face seal connection. After removing the VCR components, remember to use protective caps or gasket retainers to protect the sealing beads.

