

# ZT11

## Pressure Transmitters

### for Semiconductor Industry

#### Outline

These are pressure transmitters developed for semiconductor industry, in which pressures are converted into electric signals and transmitted by the sensing portion equipped with evaporation coating type semiconductor strain gauge and a built-in electronic circuit. It is more small and lightweight than a conventional pressure transmitter (our comparison). EP/GP grade is standard. Also conforming to the UC grade as an option.

#### Features

- Highly corrosion-resistant pressure sensors made of SUS316L are welded directly to the fitting, giving them excellent corrosion resistance, air-tightness, long-term stability, and reliability. Co-Ni alloy is optional (Only available in UC grade).

\* Please confirm that the gas contact part material is suitable for the gas to be measured.

- Dust-protected and excellent waterproof structure (IP67)
- Available in standard type and non-incendive type.



RoHS

CE

#### List of grade

**Cleanliness** These pressure transmitters have been assembled, adjusted, inspected and packaged in a clean room, paying special attention for maintaining cleanliness.

Grade		EP (Electro Polishing)	GP (General Purpose)	UC (Option) (Ultra Clean)
Surface roughness of gas contact		0.18 μm Ra Avg.	0.5 μm Ra Avg.	0.18 μm Ra Avg.
Wetted parts	Pressure sensor	SUS316L		Co-Ni alloy
	Fitting *1	SUS316L		SUS316L
Maximum allowable pressure *2		150% of rated pressure		200% of rated pressure
Leakage (Helium leak rate)		5 × 10 <sup>-12</sup> Pa · m <sup>3</sup> /s and under		5 × 10 <sup>-12</sup> Pa · m <sup>3</sup> /s and under
Particle		Zero count for size 0.1 μm or greater (In our inspection standard)	—	Zero count for size 0.1 μm or greater (In our inspection standard)
Cleaning		Ultra clearance (Cleaning)	Degreasing	Ultra clearance (Cleaning)
Operating media *3 (Recommended)		High-purity gas, semiconductor material gas, etc.	Purge gas, exhaust gas, etc.	High-purity gas, semiconductor material gas, etc.

\*1 For UC Grade (option), the pressure transmitter can be manufactured in DOUBLE MELT material by request. Please contact us.

\*2 Allowable maximum pressure is the upper limit of pressure value which may safely be applied to the product and remain in specification once pressure is returned to the rated pressure range with a couple of times overpressurization for about 10 minutes. Effects of continuous overpressure are not guaranteed.

\*3 Ensure that pressure media is compatible with wetted parts.

● EP (UC) Grade rises with double packing (Filled with N<sub>2</sub>).

## Non-incendive Pressure Transmitter Type of protection "n" **NEW**

### Outline

This is a pressure transmitter for gas supply equipment and facility used in the semiconductor manufacturing, which is type of protection "n" explosion-proof test acceptable product complied with the IECEx and ATEX Directives. This pressure transmitter can be used without the safety barrier in the places (Zone 2/Category 3G) such as a semiconductor manufacturing factory where the gas (Gas group is IIA, IIB, or IIC and temperature class is T4, T5, or T6.) might exist. In contrast to the conventional pressure transmitter, compact and lightweight (our ratio) have been realized for the Pressure Transmitters.





RoHS



### Specifications

Certifications	IECEX	ATEX
Certification number	IECEX CML 15.0067X	CML 15ATEX4148X
Hazardous area classifications	Zone 2	Category 3G
Applicable standards	IEC60079-0 : 2011 IEC60079-15 : 2010	EN60079-0 : 2012+A11:2013 EN60079-15 : 2010
Applicable directive		2014/34/EU (ATEX directive)
Explosion protection marking	<p style="text-align: center;"> <span style="margin-right: 20px;">Ex nA</span> <span style="margin-right: 20px;">IIC</span> <span style="margin-right: 20px;">T4/T5/T6</span> <span style="margin-right: 20px;">Gc</span> </p> <p style="text-align: center;"> <span style="margin-left: 100px;">Type of protection "n"</span> <span style="margin-left: 100px;">Group of gases</span> <span style="margin-left: 100px;">Temperature class</span> <span style="margin-left: 100px;">Equipment protection level</span> </p>	
Enclosure protection class	IP65 (When cable is in use)	
Breakdown voltage	500V AC for 1 minute	

### Specification

Item	Description			
Measurement fluid	Various kinds of process gases for semiconductor			
Fitting shape	Type T 	Type S 		
Connection	Compatible with 1/4 VCR, Compatible with 1/2 (3/8) VCR, 1/4 UJR			
Internal volume	Approx. 0.9cm <sup>3</sup> (In case of S type·1/4 UJR, Varies depending on the fitting shape)			
Pressure sensor seal method	Welding type			
Pressure range	0 to 0.3, 0.5, 1, 2, 3.5, 5, 10, 20 MPa -0.1 to 0.3, 0.5, 1, 2 MPa			
Electrical characteristics	Supply voltage	Standard	15 to 24V DC ±10%	
		Type of protection "n"	15 to 24V DC	
		* For relationship between supply voltage and load resistance, please refer to the numerical formula.		
	Load resistance	R max. (Ω) =50E - 500 [E: Supply voltage]		
	Output	4 to 20mA DC		
	Transmission system	2-wire system		
Accuracy	Linearity (BFSL)	±0.25%F.S. (at 23°C) or ±0.5%F.S. (at 23°C)		
	Hysteresis			
	Repeatability			
Temperature coefficient	±0.05%F.S./°C (Zero, Span)			
Operating temperature	Standard	-20 to 70°C (No freezing or condensation)		
	Type of protection "n"	Temperature class	T4	0 to 60°C (No freezing or condensation)
			T5	0 to 50°C (No freezing or condensation)
T6			0 to 35°C (No freezing or condensation)	
Storage temperature	Standard	-30 to 80°C (No freezing or condensation)		
	Type of protection "n"	-20 to 80°C (No freezing or condensation)		
Insulation resistance	100MΩ or more (50V DC between joint and all input output terminals)			
EMC Applicable standards	EN61326-1: 2013; EN61326-2-3: 2013 * Please use it to connect to the indoor power distribution network which is not affected by the lightning surge voltage and power supply system switching transients.			
Electrical connections	M12 Connector connection (4 pin)			
Construction	Standard	IP67 (When connector mating/IEC 60529)		
	Type of protection "n"	IP65 (When connector mating/IEC 60529)		
Zero/Span adjustment mechanism	External adjustment method (Top surface)			
Weight	Approx. 70g (In case of S type, Excluding cable, Varies depending on the fitting shape)			

### Electrical connection

Connector terminal array	Terminal number	2-wire system	Cable color
	1	Power source (+)	Brown
	2	—	White
	3	Power source (-)	Blue
	4	—	Black

### Wiring

#### 2-wire system

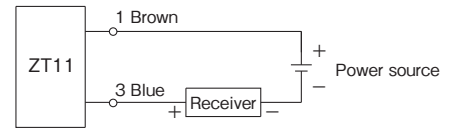

#### 2-wire system Terminal distribution

- 1 - Brown: Power source (+)
- 3 - Blue: Power source (-)

### M12 cable with connector (Optional)

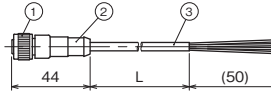
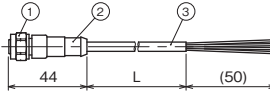
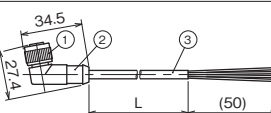
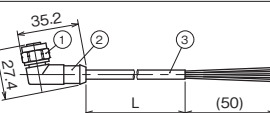
	PUR cable (Oilproof)	PVC cable (Stainless nut)
Straight		
Type L		
Material	<ul style="list-style-type: none"> <li>① Zinc die casting (Nickel plating)</li> <li>② TPU (Green)</li> <li>③ PUR</li> </ul>	<ul style="list-style-type: none"> <li>① Stainless</li> <li>② TPU (Black)</li> <li>③ PVC</li> </ul>
Cable length (L)	3m or 5m	3m or 5m
Cross-section area of conductor	0.34mm <sup>2</sup> (22AWG)	0.34mm <sup>2</sup> (22AWG)
Core diameter including insulation	1.27mm	1.52mm
External cable diameter	4.7mm	5.2mm

\* The protection structure of the cable with the M12 connector is protection class in a mating state.

### Caution

[Standard]

Do not install at facility where that is liable to cause an explosion or fire in normal condition.

### Dimensions 1

Unit: mm

#### Type T

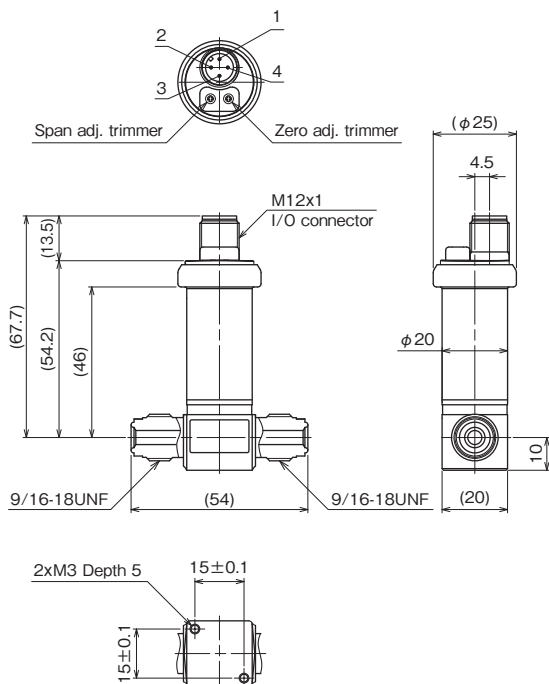

Compatible with 1/4 VCR

ZT11-C3   
ZT11-X3

#### Type T

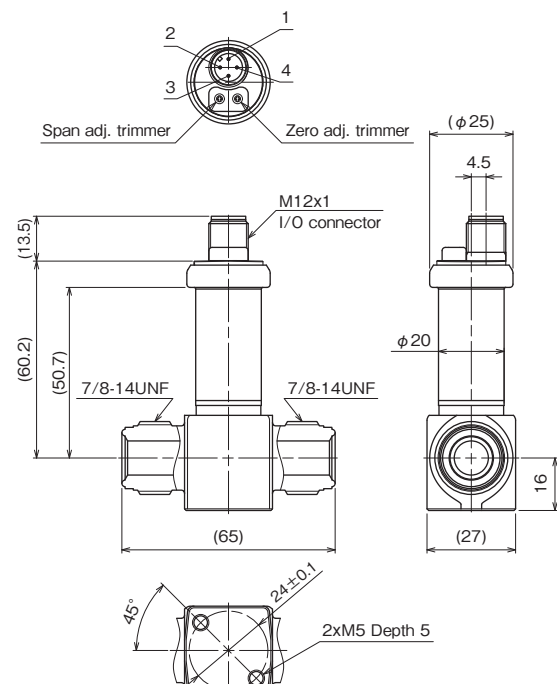

Compatible with 1/2 (3/8) VCR

ZT11-C4   
ZT11-X4

The dimension in the catalog are subject to change without notice.

### Dimensions2

Unit: mm

Type S

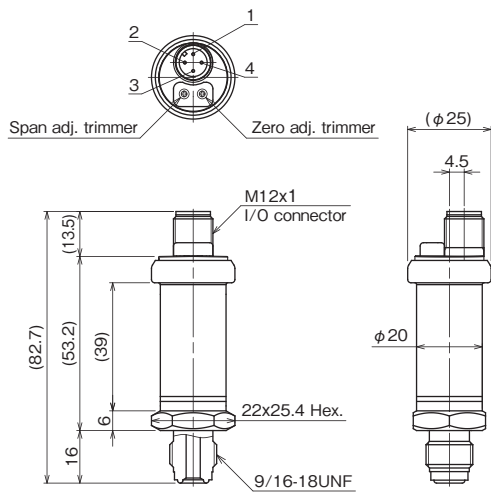

Compatible with 1/4 VCR

ZT11-D3   
ZT11-Y3

Type S

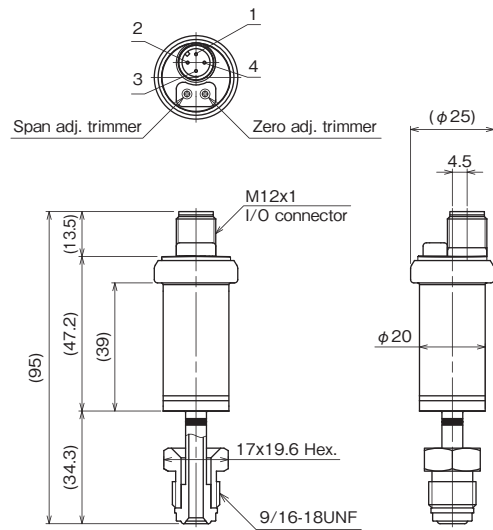

1/4 UJR

ZT11-DN   
ZT11-YN

Type S

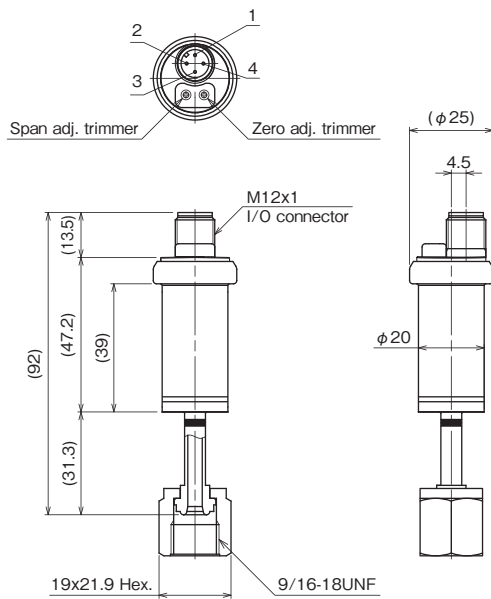

1/4 UJR

ZT11-DQ   
ZT11-YQ

The dimension in the catalog are subject to change without notice.

### Supply voltage and load resistance

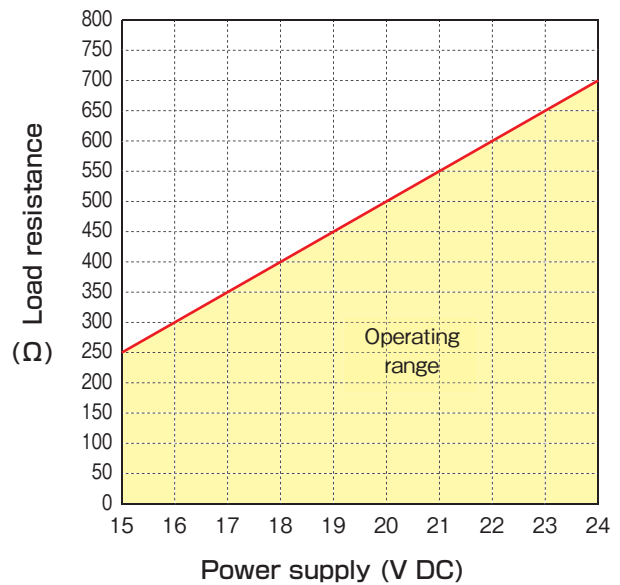

R max. (Ω) = 50E - 500 [E: Supply voltage]

### Pressure Transmitters, EP · GP Grade

#### Model number configuration

Please specify the model number, each specs and the range for ordering.

Model		<div style="display: flex; align-items: center; gap: 10px;"> <div style="border: 1px solid black; padding: 5px; font-weight: bold; font-size: 1.2em;">Z T 1 1</div> <span>—</span> <div style="display: flex; gap: 5px;"> <div style="width: 20px; height: 20px; background-color: #f96;"></div> <div style="width: 20px; height: 20px; background-color: #f96;"></div> <div style="width: 20px; height: 20px; background-color: #f96;"></div> </div> <span>—</span> <div style="display: flex; gap: 5px;"> <div style="width: 20px; height: 20px; background-color: #f96;"></div> <div style="width: 20px; height: 20px; background-color: #f96;"></div> <div style="width: 20px; height: 20px; background-color: #f96;"></div> <div style="width: 20px; height: 20px; background-color: #f96;"></div> <div style="width: 20px; height: 20px; background-color: #f96;"></div> <div style="width: 20px; height: 20px; background-color: #f96;"></div> <div style="width: 20px; height: 20px; background-color: #f96;"></div> <div style="width: 20px; height: 20px; background-color: #f96;"></div> <div style="width: 20px; height: 20px; background-color: #f96;"></div> <div style="width: 20px; height: 20px; background-color: #f96;"></div> <div style="width: 20px; height: 20px; background-color: #f96;"></div> <div style="width: 20px; height: 20px; background-color: #f96;"></div> <div style="width: 20px; height: 20px; background-color: #f96;"></div> <div style="width: 20px; height: 20px; background-color: #f96;"></div> <div style="width: 20px; height: 20px; background-color: #f96;"></div> </div> </div>																
Pressure Transmitter EP · GP Grade		①	②	③	④	⑤	⑥	⑦	⑧	⑨	⑩	⑪	⑫	⑬	⑭	⑮		
Model number		Selective spec.					Additional spec. (Option)											
① Mounting	C	Type T, Standard					Construction: IP67 EMC compliant products											
	D	Type S, Standard					Construction: IP67 EMC compliant products											
	X	Type T, Type of protection "n" (IECEX/ATEX)					Construction: IP65 CE marking compliant products											
	Y	Type S, Type of protection "n" (IECEX/ATEX)					Construction: IP65 CE marking compliant products											
② Connection of fitting	3	1/4	Compatible with VCR Male integrated														Type S	Type T
	4	1/2 (3/8)	Compatible with VCR Male integrated														×	○
	N	1/4	UJR Male nut														○	×
	Q	1/4	UJR Female nut (Without pure ring)														○	×
③ Wetted parts by grade	E	EP Grade · Pressure sensor: SUS316L (All welding) · Fitting: SUS316L																
	G	GP Grade · Pressure sensor: SUS316L (All welding) · Fitting: SUS316L																
④ Pressure range	C	-0.1 to 0.3MPa																
	D	-0.1 to 0.5MPa																
	E	-0.1 to 1MPa																
	F	-0.1 to 2MPa																
	1	0 to 0.3MPa																
	2	0 to 0.5MPa																
	3	0 to 1MPa																
	4	0 to 2MPa																
	5	0 to 3.5MPa																
6	0 to 5MPa																	
7	0 to 10MPa																	
8	0 to 20MPa																	
⑤ Accuracy	V	±0.25%F.S. (Temperature coefficient: ±0.05%F.S./°C)																
	5	±0.5%F.S. (Temperature coefficient: ±0.05%F.S./°C)																
⑥ Power source	P	15 to 24V DC ±10% (Standard)																
		15 to 24V DC (Type of protection "n")																
⑦ Output	1	4 to 20mA DC (2-wire system)																
⑨ M12 connector cable	0	Nil																
	1	PUR cable (Oilproof)	Straight															Cable length 3m
	2		L type															
	3	PVC cable (Stainless nut)	Straight															Cable length 5m
	4		L type															
	5	PUR cable (Oilproof)	Straight															Cable length 5m
	6		L type															
	7	PVC cable (Stainless nut)	Straight															Cable length 5m
8	L type																	
⑮ Documents	0	Nil																
	1	Required (Please specify the desired documents separately.) Submission drawings, instruction manual, inspection procedure, mill sheet, test report (1 pc 1 copy), inspection / traceability certificate, strength calculation, attended inspection																

Please specify the pressure range and units separately besides selection of range code.

Optional UC grade version available. Please contact us after confirming application and basic specifications of the grade for its use.

\* Specify "X" if there is no applicable specification.